

**ALTRONIC, INC.
712 TRUMBULL AVE.
GIRARD, OHIO 44420**

**ALTRONIC V IGNITION SYSTEM
4400 SERIES - S/N 4400 & UP**

IMPORTANT SAFETY NOTICE

PROPER INSTALLATION, MAINTENANCE, REPAIR AND OPERATION OF THIS EQUIPMENT IS ESSENTIAL. THE RECOMMENDED PRACTICES CONTAINED HEREIN SHOULD BE FOLLOWED WITHOUT DEVIATION. AN IMPROPERLY INSTALLED OR OPERATING IGNITION SYSTEM COULD CAUSE PERSONAL INJURY TO OPERATORS OR OTHER NEARBY PERSONNEL.

TABLE OF CONTENTS**ALTRONIC V SERVICE MANUAL**

SECTION	ITEM	PAGE
1.0	SYSTEM DESCRIPTION	3
2.0	PARTS IDENTIFICATION AND SPECIFICATION	4
2.1	Parts List	5
2.2	Part No. Designation	6
2.3	Unit Specifications	6
3.0	PERFORMANCE SPECIFICATIONS	7
3.1	Voltage Test	7
3.2	Operating Test	7
3.3	Timing Specifications	7
4.0	TROUBLESHOOTING	8
4.1	Circuit Diagram	8
4.2	Oscilloscope Testing	9
4.3	Procedure	10
4.4	One Output Does Not Fire	10
4.5	System Has Weak or No Output	10
5.0	SERVICE - ALTERNATOR SECTION	10
5.1	Disassembly	10
5.2	Parts Replacement	10
5.3	Reassembly	11
6.0	SERVICE - BACK COVER ASSEMBLY	12
6.1	Circuit Board Assembly Replacement	12
6.2	Pickup Coil Assembly Replacement	12
6.3	Driven Gear/Magnet Arm Assembly	13
6.4	Driven Shaft, Bearing	13
6.5	Reassembly - Driven Shaft Assembly	13
6.6	Reassembly - Back Cover to Alternator	14
7.0	SERVICE-ASSEMBLY TOOLS	15
8.0	OPERATIONAL TEST	15

1.0 ALTRONIC V IGNITION SYSTEM - DESCRIPTION

Altronic V is an alternator powered, electronic ignition system. All electronic parts are mounted to the back cover which disconnects as a module from the alternator section.

The alternator (A) provides the power to charge energy storage capacitor (B). A separate pickup coil (C) and SCR (D) are used for each of the system's outputs which correspond usually to each engine cylinder. A rotating timer arm (E) driven through speed reducing gears (F) passes over the pickup coils to trigger on the SCR switches in sequence. This releases the capacitor's stored energy to the ignition coils which step up the voltage to fire the spark plugs.

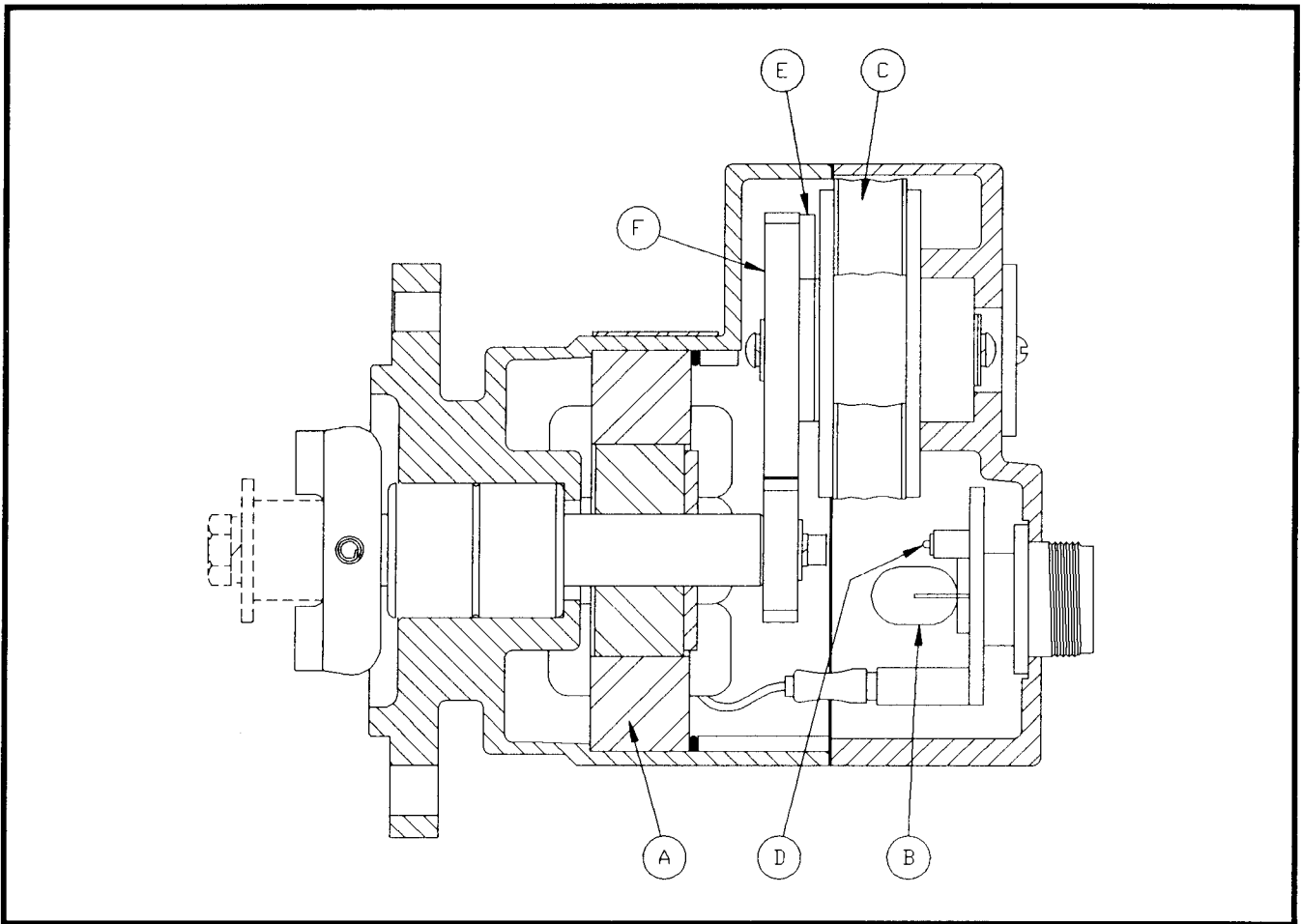

CROSS SECTIONAL VIEW - ALTRONIC V UNIT

- | | |
|------------------------------|---------------------------|
| A - Alternator | D - SCR electronic switch |
| B - Energy storage capacitor | E - Timer arm |
| C - Pickup coil | F - Distribution gears |

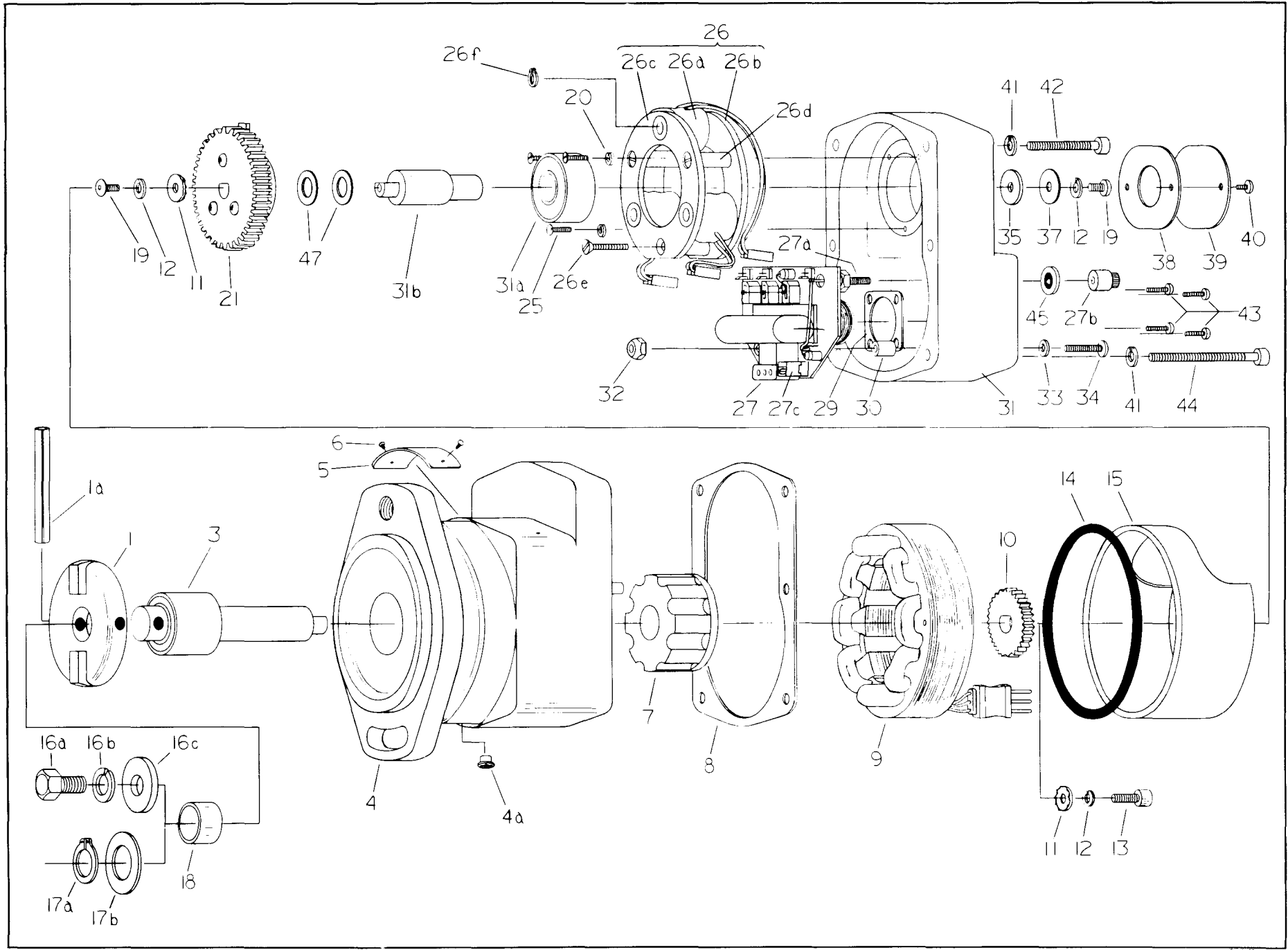

2.0 PARTS IDENTIFICATION AND SPECIFICATION

2.1 PARTS LIST - ALTRONIC V - Reference the exploded view on page 4.

REF. NO.	PART NO.	DESCRIPTION	REF. NO.	PART NO.	DESCRIPTION	
1	510 454-U	Coupling, yellow	26c	570 010	Plate-bushing ass'y. 3A	
	510 699	Coupling (109-8912 only)		570 011	Plate-bushing ass'y. 2A	
1a	902 478	Spring pin 2-1/8" lg.		570 012	Plate-bushing ass'y. 1A	
3	410 063	Bearing-shaft (-A,-AM,-D)		570 020	Plate-bushing ass'y. 4A	
	510 654	Bearing-shaft (-AW,-GVW)		570 021	Plate-bushing ass'y. 5A	
4	560 004-1	Housing (-A,-AM,-AW)		570 022	Plate-bushing ass'y. 6A	
	560 004-2	Housing (-GV,-GVW)	26d	510 627	Spacer - 1A, 2A, 3A	
	560 004-3	Housing (-D)		510 651	Spacer - 4A, 5A, 6A	
	560 004-4	Housing (-GVC)	26e	902 574	Screw 6-32	
	560 004-5	Housing (109-8912)	26f	610 117	Snap ring	
4a	510 541	Ventilator	27	See pg. 6	Circuit board assembly	
5	502 134	Nameplate - 2.0" X 1.9"	27a	301 208-2	Zener diode (10M120Z5)	
	502 168	Nameplate - 3.5" X 1.1"		301 233-3	Zener diode (10M150Z5)	
6	902 520	Drive pin	27b	504 161	Nut 10-32, zener diode	
7	160 001	Magnet-rotor	27c	583 007	Plug assembly	
8	410 039	Gasket		29	501 335	Gasket, 5-pin connector
	571 003	Stator	501 368		Gasket, 7-pin connector	
10	310 518	Drive gear 1.5:1	30	510 597	Spacer	
	510 357	Drive gear 2:1		31	570 005	Rear cover, 5-pin conn.
	510 359	Drive gear 3:1			570 028	Rear cover, 7-pin conn.
	510 625	Drive gear 1:1			570 029-1	Rear cover, 5-pin w/timing
901 326	Washer	570 029-2	Rear cover, 7-pin w/timing			
11	901 326	Washer	31a	410 058	Bearing	
12	900 944	Lockwasher #8	31b	510 660	Shaft, driven	
13	902 465	Screw 8-32	32	902 459	Nut 6-32	
14	510 462	O-ring	33	902 602	Washer	
15	410 038	Spacer	34	902 565	Screw 6-32	
16a	902 585	Screw 5/16"-18	35	902 591	Washer	
16b	901 010	Lockwasher 5/16"	37	302 106	Timing label, shaft	
16c	902 586	Washer	38	502 142	Timing label, cover	
17a	902 487	Snap ring	39	310 365	Cover plate	
17b	902 503	Washer	40	902 058	Screw 6-32	
18	410 045	Spacer	41	901 004	Lockwasher	
19	902 541	Screw 8-32	42	902 567	Screw 10-24 X 1.25"	
20	900 996	Lockwasher #4		902 587	Screw 10-24 X 2.0"	
21	570 017-1	Driven gear ass'y. 1:1	43	902 064	Screw 6-32	
	570 017-2	Driven gear ass'y. 2:1	44	902 483	Screw 10-24	
	570 017-3	Driven gear ass'y. 3:1	45	902 645	Washer, sealing	
	570 017-6	Driven gear ass'y. 1.5:1	47	902 579	Washer, shim	
25	902 564	Screw 4-40	*	562 001	Connector assembly	
26	570 401	Pickup plate ass'y. 1A	*	501 369	Gasket	
	570 402	Pickup plate ass'y. 2A	*	900 966	Lockwasher	
	570 403	Pickup plate ass'y. 3A	*	902 525	Screw 4-40	
	570 404	Pickup plate ass'y. 4A				
	570 405	Pickup plate ass'y. 5A				
	570 406	Pickup plate ass'y. 6A				
26a	See pg. 12	Pickup coil ass'y.				
26b	570 008	Plate-core ass'y. 2A				
	570 009	Plate-core ass'y. 3A				
	570 015	Plate-core ass'y. 1A				
	570 025	Plate-core ass'y. 4A				
	570 026	Plate-core ass'y. 5A				
	570 027	Plate-core ass'y. 6A				

* Parts for units with electronic timing option (not illustrated).

NOTE: Reference numbers with a letter suffix are part of the assembly of the same number without the suffix. Example: (1a) is part of (1).

2.2 PART NO. DESIGNATION

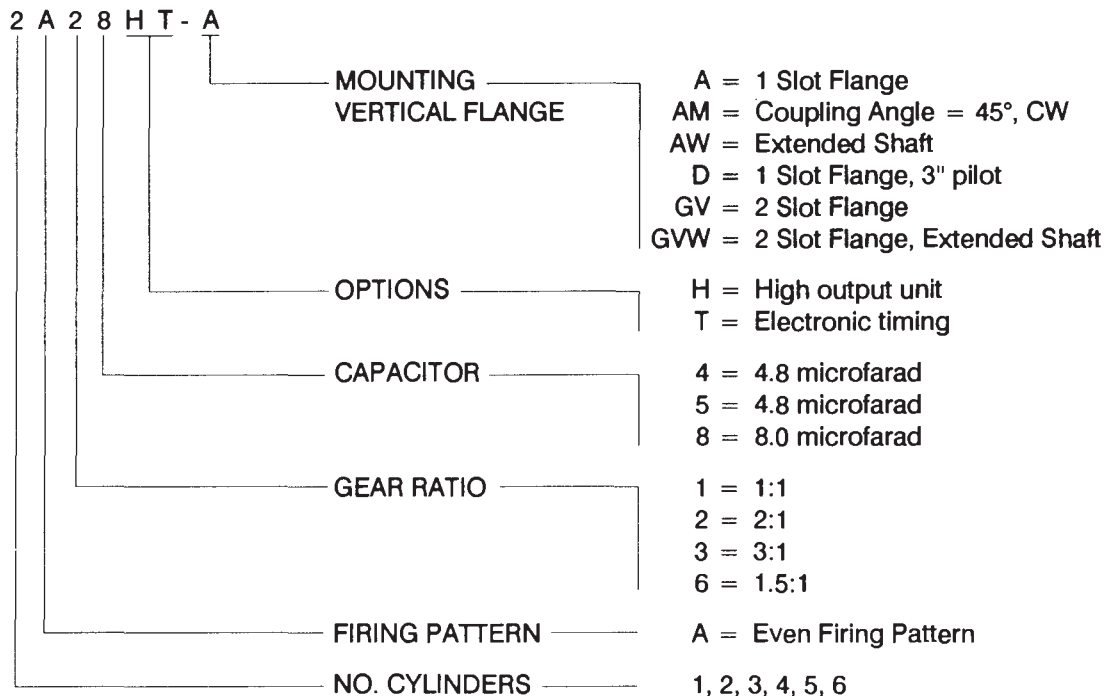

2.3 UNIT SPECIFICATIONS

NOTE: It is recommended that 581 40x circuit boards be updated (exchanged) for the 572 61 x series.

UNIT NO.	BACK COVER	CIRCUIT BOARD ASS'Y. (27)
1A18	581 401-1	572 612
1A28	581 401-2	572 612
1A28H	581401-2H	572 612H
2A14	581 404-1	572 613
2A18H	581 402-2H	572 612H
2A25	581 404-3	572 613
2A28	581 402-1	572 612
2A28H	581 402-1H	572 612H
2A64	581 404-2	572 613
3A14	581 406-2	572 613
3A25	581 406-4	572 613
3A35	581 406-3	572 613
3A64	581 406-1	572 613
4A24	581 407-1	572 614
4A34	581 407-2	572 614
5A24	581 405-1	572 616
6A24	581 408-2	572 616
6A34	581 408-1	572 616
61-2611*	581 407-2	572 614 (Follow testinQ for 4A34)
328-8382*	581 407-2	572 614 (Follow testing for 4A34)
9Y-6465*	581 408-1	572 616 (Follow testing for 6A34)
109-8912*	581 408-2	572 616 (Follow testing for 6A24)

* Caterpillar OEM units.

3.0 PERFORMANCE SPECIFICATIONS:

- A. Install unit on a test stand equipped with a suitable number of 501 061 coils and spark gaps. Test stand wiring should conform to that shown in the Installation Instructions form AV II for 6-cylinder engines.

3.1 VOLTAGE TEST

- A. With the wiring harness unplugged, measure the positive voltage at the connector "G" pin:

UNIT SPEED	CIRCUIT BOARD NO.	CONNECTOR PIN	VOLTAGE OUTPUT
500 rpm	572 602, 572 612	"E"	111-129 VDC
	572 602H, 572 612H	"E"	140-160 VDC
	572 603, 572 613	"E"	140-160 VDC
	572 604, 572 614	"G"	140-160 VDC
	572 606, 572 616	"G"	140-160 VDC

3.2 OPERATING TEST

- A. At 90-120 RPM, a 7mm gap should fire consistently.
 B. At the TEST RPM, a 15mm gap should fire consistently.

3.3 TIMING SPECIFICATIONS

- A. Timing should be as specified in the table below as measured on a standard ignition test stand with the degree wheel indicator rotating at the unit coupling speed.
 B. If timing is out of specification, change the pick-up coil (31) in question.

UNIT NO.	COUPLING TEST RPM	COUPLING ROTATION	FIRING SEQUENCE DEGREES						TOLERANCE +/-	
			A	B	C	D	E	F		
1A18	1,300	CW	0*							-
1A28	1,300	CW	0**							-
1A28H	1,300	CW	0**							-
2A14	2,000	CW	0	180						2
2A18H	700	CW	0	180						2
2A25	2,400	CW	0	0						2
2A28	1,300	CW	0	0						2
2A28H	1,300	CW	0	0						2
2A64	3,000	CW	0 180	90 270						3
3A14	2,000	CW	0	120	240					2
3A25	2,000	CW	0	240	120					2
3A35	3,000	CW	0	0	0					3
3A64	3,000	CW	0 180	0 180	0 180					3
4A24	2,000	CW	0	180	0	180				2
4A34	3,000	CW	0	270	180	90				3
5A24	2,000	CW	0	144	288	72	216			2
6A24	2,000	CW	0	120	240	0	120	240		2
6A34	3,000	CCW	0	180	0	180	0	180		3

* 15-17 degree retard at low speed.

** 30-34 degree retard at low speed.

4.0 TROUBLESHOOTING

4.1 CIRCUIT DIAGRAM

- A. The diagram below shows the Altronic V circuit for one cylinder. Each component in the Timing-Distribution section (to the right of the dashed line) is present in a quantity equal to the number of system outputs; each output requires a pick-up coil assembly, capacitor C3 and power SCR2.
- B. The operation is as follows: The AC voltage generated by the alternator is converted to DC by diodes D1 and stored in the energy storage capacitor C1. The DC voltage level is regulated by zener diode Z. Capacitor C2 is charged through resistor R1 to provide the energy to trigger power SCR2. This occurs when the rotating distributor arm passes a pick-up coil (P) triggering on SCR1 and connecting capacitor C2 through resistor R3 to the gate of SCR2. SCR2 then turns on discharging capacitor C1 into the primary of the ignition coil which steps up the voltage to fire the spark plug. Capacitor C3 acts as a filter to prevent crossfiring between outputs.

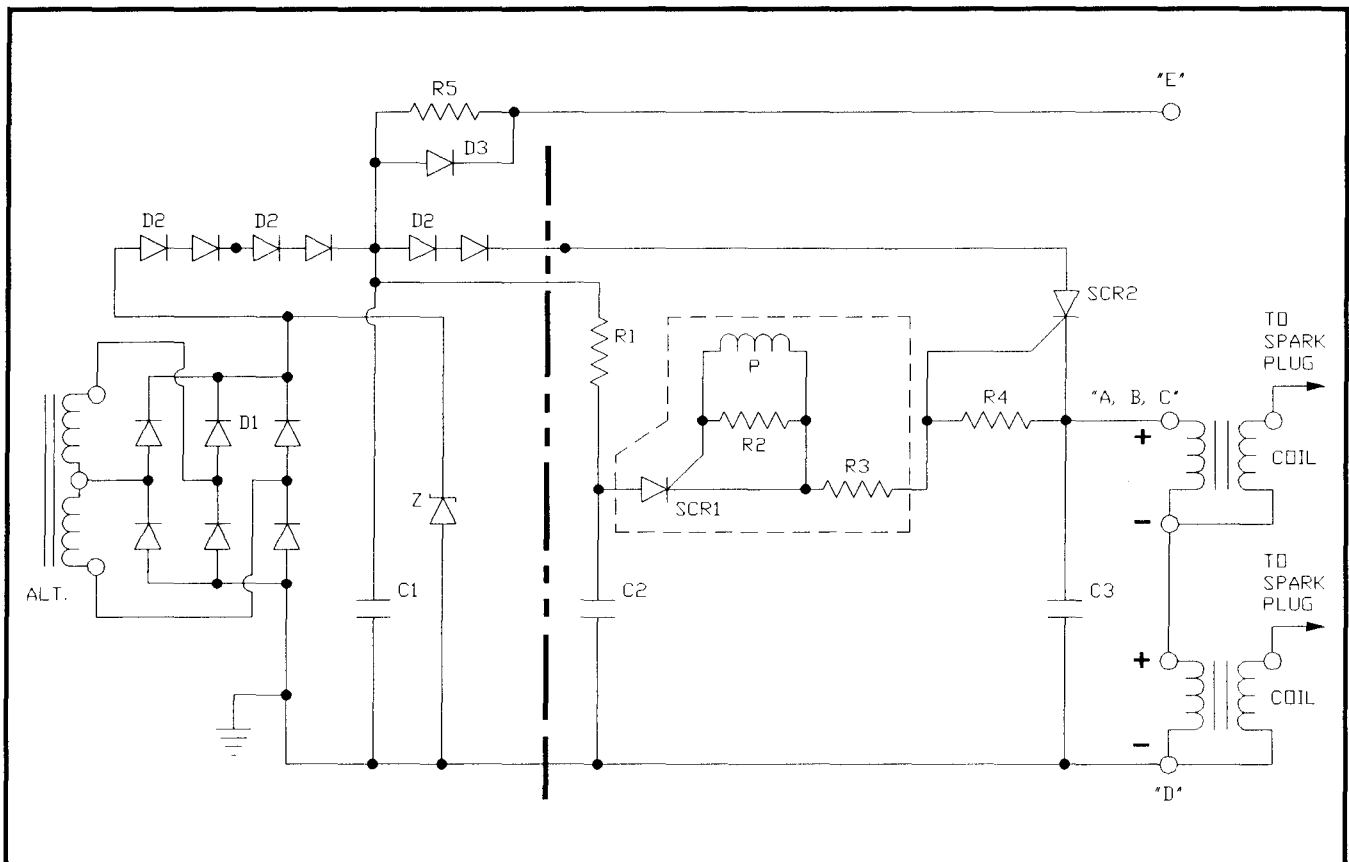

C. Components:

C1	Capacitor, energy storage
C2	Capacitor, trigger
C3	Capacitor, filter
D1	Diode
D2	Diode, dual
D3	Diode, blocking

SCR1,P,R2,R3	Pick-up coil assembly
SCR2	Power SCR
R1	Resistor, trigger circuit
R4	Resistor, SCR gate
R5	Resistor
Z	Zener diode

4.2 OSCILLOSCOPE TESTING - The system should be fully connected per section 3.0 with the Altronic V unit operating at the TEST RPM given in section 3.3. Connect the oscilloscope probe to the shutdown lead of the output connector - "E" for the 5-pin connector or "G" for the 7-pin connector. Set the oscilloscope vertical calibration to 50 volts/div.; adjust the time base to get a full cycle of firings on the screen: No. of discharges = number of outputs for the unit.

A. STORAGE CAPACITOR PATTERN: NORMAL - The normal patterns for typical 3-output (3A64) and 6-output (6A34) units are shown below.

3-OUTPUT UNIT - 3A64

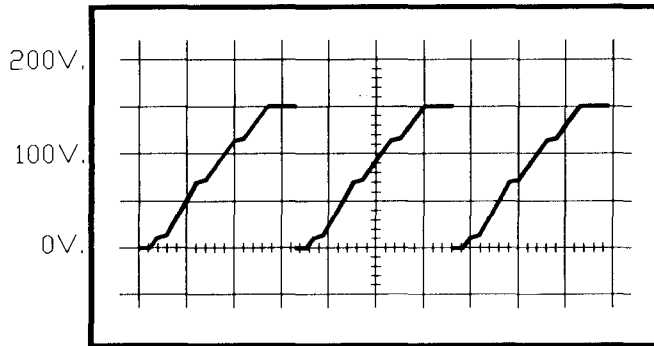

6-OUTPUT UNIT - 6A34

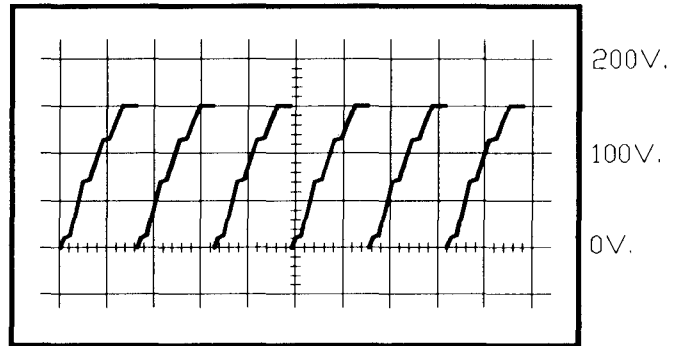

B. STORAGE CAPACITOR PATTERN: ABNORMAL - One cylinder misfiring. See troubleshooting section 4.4.

3-OUTPUT UNIT - 3A64

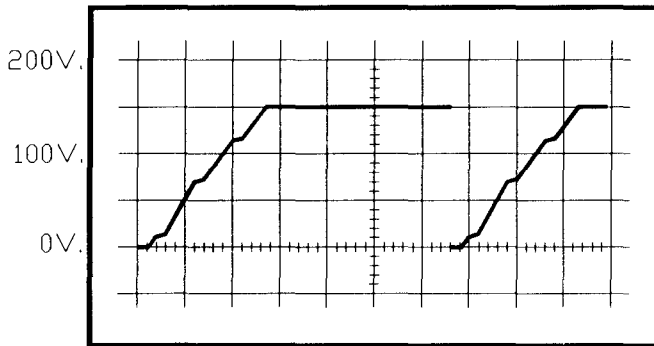

6-OUTPUT UNIT - 6A34

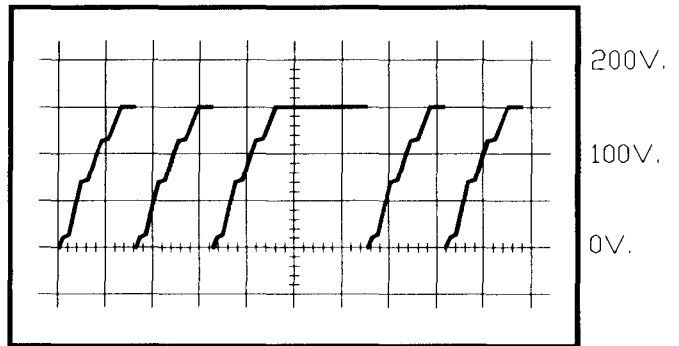

C. STORAGE CAPACITOR PATTERN: ABNORMAL - Irregular waveform. See troubleshooting section 4.5.

3-OUTPUT UNIT - 3A64

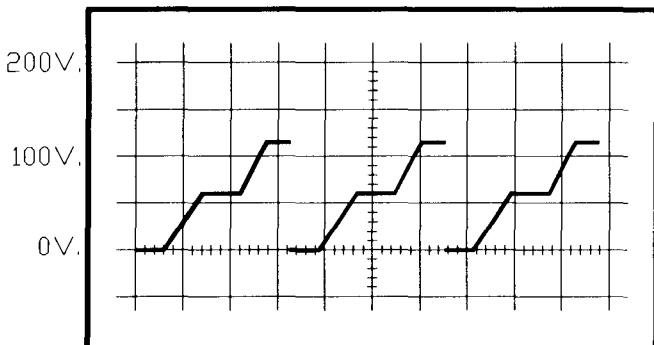

6-OUTPUT UNIT - 6A34

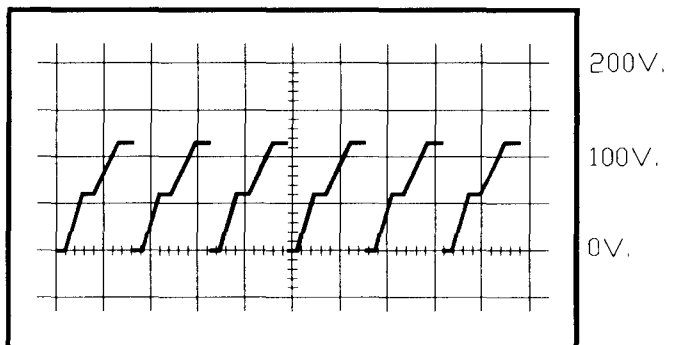

4.3 PROCEDURE

- A. See section 3.0-3.3 for proper performance.
- B. Use Simpson model 260 meter on RX10,000 scale unless otherwise specified.
- C. First discharge all capacitors. Carefully use a screwdriver to short from the connector shell first to the "E" pin on 5-pin connector or "G" pin on 7-pin connector, then to all other pins.

4.4 ONE OUTPUT DOES NOT FIRE

- A. Check that the 2-lead pickup coil connector is fully plugged into the circuit board receptacle.
- B. Check with ohmmeter as follows: Positive lead to case; negative lead to connector pin with no output. Move the timer arm (21a) past the pickup coil corresponding to the test connector pin ("A" is red; "B", "C", etc. follow in a CW direction from "A"); meter should pulse indicating pickup coil output. If not, replace pickup coil assembly (26a) - see section 6.2.
- C. If above tests are OK, replace circuit board assembly (27) - see section 6.1.

4.5 SYSTEM HAS WEAK OR NO OUTPUT

- A. Check stator (9) resistance - replace if defective - see section 5.0.
 - 1. Center pin to outer pin: 450-650 ohms (RX100 scale)
 - 2. Center pin to other outer pin: 5000-6000 ohms
 - 3. Center pin to lamination core: infinite

5.0 SERVICE - ALTERNATOR SECTION

- A. The unit breaks down into two major parts: the Alternator Section and the Back Cover Assembly. Remove the four back cover attaching screws (42), (44) and carefully pull the back cover assembly away from the alternator housing; unplug the 3-prong internal connector.
- B. The procedures of this section require the use of an arbor press.

5.1 DISASSEMBLY

- A. Remove the phenolic spacer (15), O-ring (14) and stator (9) from the alternator housing.
- B. -AW/-GVW UNITS ONLY: Remove hardware (16a), (16b), (16c) or (17a), (17b) and sleeve (18) from unit shaft.
- C. Drive spring pin (1a) out of coupling (1) and shaft and remove coupling.
- D. Remove screw (13), lockwasher (12), washer (11) and drive gear (10).
- E. If it is necessary to replace bearing-shaft (3), support the housing on the coupling end and press shaft out of the magnet-rotor assembly and housing.
- F. Wrap magnet-rotor assembly (7) in a cloth or paper to keep it clean.

5.2 PARTS REPLACEMENT

- A. Replace gasket (8).
- B. Replace coupling (1) and bearings (3) and (31a) with new parts.
- C. Replace any removed hardware with new parts.
- D. Aluminum housings should be cleaned with carbon tetrochloride or similar cleaning solution.
- E. Any metal filings should be cleaned from magnet-rotor (7) before reassembly.

5.3 REASSEMBLY - ALTERNATOR SECTION

- A. Press new bearing-shaft (3) into housing (4) until it bottoms against shoulder. Housing (4) should be supported behind the internal shoulder with tool no. 506 101B. Push on the outer race of the bearing using tool 506 101A.
- B. Clean all debris from the magnet-rotor assembly (7).
- C. Slide magnet-rotor assembly (7) over shaft with plate facing out as shown below. Support the shaft on the coupling end using tool no. 506 102B and, using tool no. 506 102C, press magnet-rotor assembly (7) on the shaft 0.575" past the shoulder for the drive gear.
- D. Slide coupling (1) onto the shaft and secure with spring pin (1a) through the coupling and shaft.
- E. -AW/-GVW UNITS ONLY: Install sleeve (18) and engine gear. Secure with hardware (16a), (16b), (16c) or (17a), (17b) - see page 4.
- F. Inspect gear (10); replace if worn. Secure with new hardware (11), (12), and (13).
- G. Reinstall stator with leads at the 6 o'clock position, a new O-ring (14) and spacer (15).

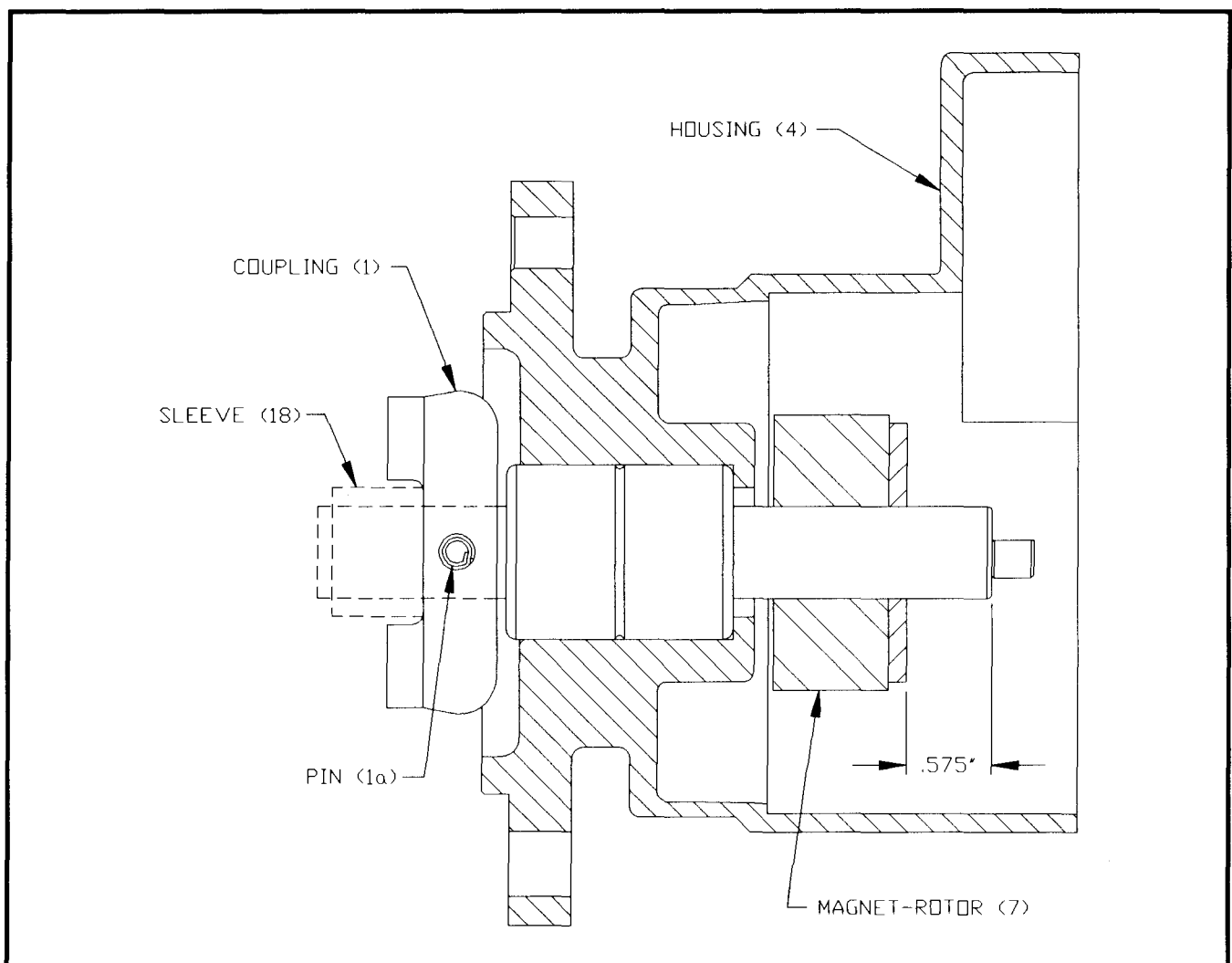

6.0 SERVICE - BACK COVER ASSEMBLY

- A. Replace only those parts requiring service.

6.1 CIRCUIT BOARD ASSEMBLY (27) - REPLACEMENT

- A. Use a small screwdriver to pull the circuit board receptacle levers away from the 2-lead housing of the pickup coil connectors; then unplug the pickup connectors from the circuit board (27).
- B. Remove four screws (43), zener diode nut (27b) and washer (45), screw (34), washer (33) and nut (32). The circuit board can then be removed from the cover. Keep track of spacer (30).
- C. Reverse steps 5.1A and 5.1B to reassemble.
- NOTE: Use new parts for washers (33) and (45) - see page 5.

6.2 PICKUP COIL ASSEMBLY (26a) - REPLACEMENT

- A. Remove hardware (19), (12), (11) holding the driven gear/magnet arm assembly. Pull driven gear/magnet-arm assembly (21) from the driven shaft.
- B. Unplug the pickup coil connector in question - see 6.1A.
- C. To replace a pickup coil (26a), remove three screws (26e) and plate assembly (26c). On 1-cylinder units only, remove the small snap ring (26f). Then remove the pickup coil in question.
- D. When installing the new pickup coil, the end with the marked line must face out against plate (26c). Rotate the coil body so that the bulge does NOT face inside the circle of the O.D. of the bearing (31a) - see orientation as shown below.
- E. To reinstall top plate (26c), insert screws (26e) through plate (26c) and spacers (26d) into the plate-core assembly (26b); then tighten screws (26e).
- F. Plug the pickup coil connector into the circuit board receptacle.

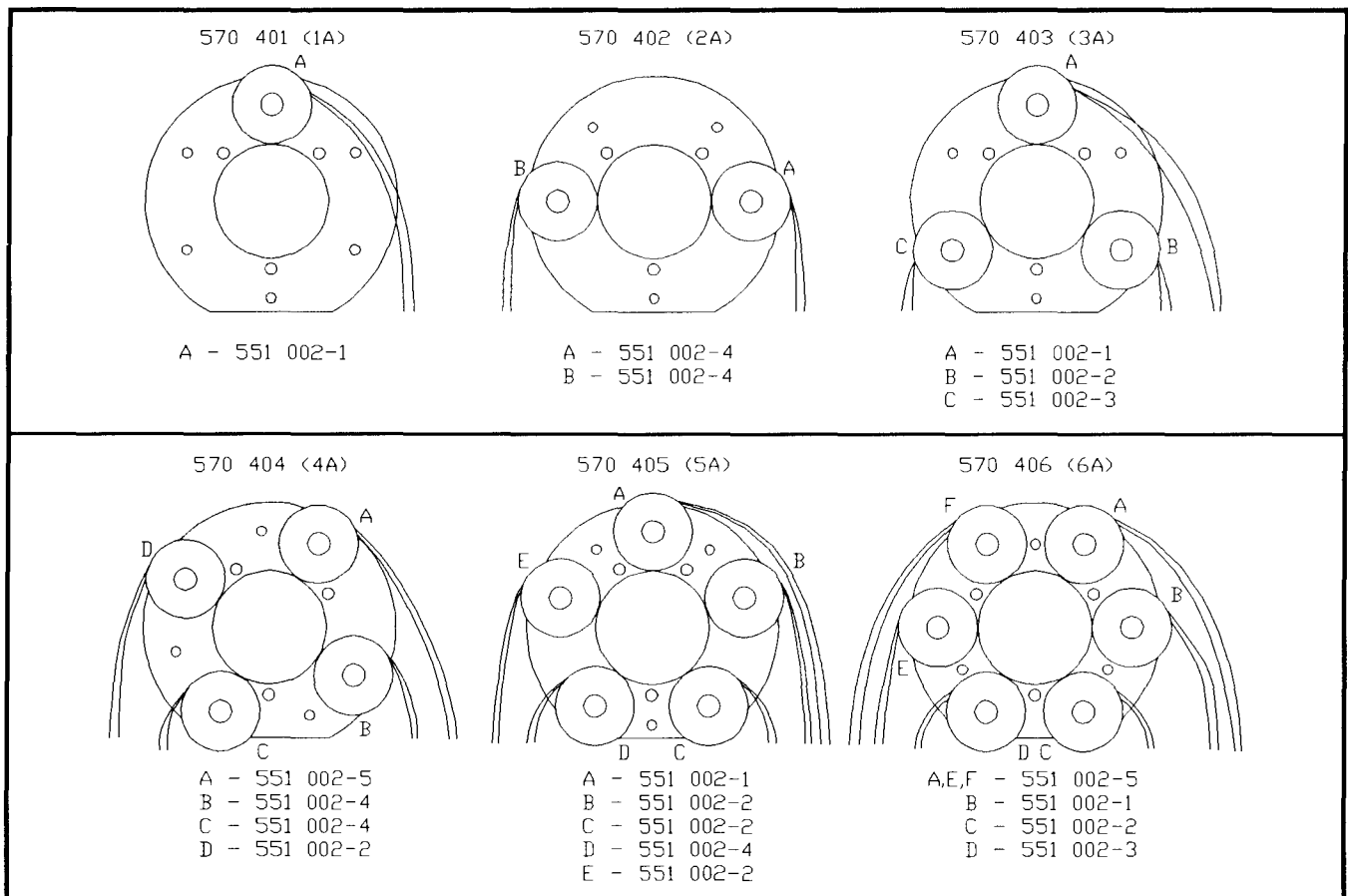

6.3 DRIVEN GEAR/MAGNET ARM ASSEMBLY (21)

NOTE: Early-production assemblies having the driven gear held to the magnet-arm with slotted pan-head screws should be updated to the equivalent one-piece driven gear/magnet-arm assembly (21).

- A. Remove screw (19) and pull driven gear/magnet-arm assembly (21) from shaft (31b). DO NOT loosen the three small button-head, hex-socket screws holding the gear assembly together. Keep track of shim washers (47).

6.4 DRIVEN SHAFT (31b), BEARING (31a)

NOTE: It is recommended that all units be updated to the current design press-fit secured driven shaft (31b).

- A. The procedures of this section require the use of a small arbor press.
- B. Remove the driven gear assembly (21) per section 6.3.
- C. Unplug the pickup coil connectors - see step 6.1A.
- D. Remove three screws (25) and lockwashers (20). Then pull the entire pickup plate assembly (26) off bearing (31a).
- E. Remove cover plate (39) and timing decal (37).
 - SNAP-RING SECURED DRIVEN SHAFT - Remove snap ring and pull driven shaft assembly from bearing (31a).
 - PRESS-FIT SECURED DRIVEN SHAFT - Press shaft (31b) out of bearing (31a).
- F. Press bearing (31a) out of rear housing (31).
- G. Support housing (31) with tool 506 103B; slide bearing (31a) over guide of tool no. 506 103B and press bearing into housing with tool no. 506 103A until it bottoms.
- H. Support bearing (31a) on the inner race with tool 506 104B and press, using tool 506 104A, on the gear shoulder of shaft (31b) until the shaft bottoms against bearing.

6.5 REASSEMBLY - DRIVEN SHAFT ASSEMBLY

- A. Reinstall the pickup plate assembly (26) and secure with hardware (20) and (25).
- B. Plug the pickup connectors into the circuit board receptacles.
- C. Slip shims (47) - the same number as removed, if any - over the end of shaft (31b) against shoulder.
- D. Check that the air gap between the rotating arm and the plate (26c) is .005"-.018". If the air gap requires adjustment, first remove screw (19) holding the driven gear and pull the assembly (21) from the shaft. Add or subtract a shim washer (47) to increase or decrease the air gap. Reinstall assembly (21) and secure with hardware (11), (12) and (19).
- E. Using a small brush, apply a thin coat of silicone compound (GC type 5Z; Altronic part no. 503 259) to the teeth of the driven gear (21).
- F. Install washer (35), timing decal (37), lockwasher (12) and screw (19) but tighten screw so that the lockwasher just starts to compress.
- G. Place the timing arm (21) centered on the red pickup coil core. The red mark on decal (37) should be placed midway between the CCW and CW marks of the label. Tighten screw (19).
- H. Install cover plate (39) and secure with two screws (40).

6.6 REASSEMBLY - BACK COVER TO ALTERNATOR SECTION

- A. Set the back cover assembly with the timing mark aligned to either CCW or CW as required for the application. Set the alternator coupling angle as shown in the chart below.
- B. Mate the back cover to the alternator keeping the alignment of the back cover timing mark and alternator coupling as set in step 6.6A.
- C. Secure the back cover to the alternator keeping the alignment of the back cover timing mark to the alternator with hardware (41), (42) and (44).

BACK COVER
TIMING INDICATOR

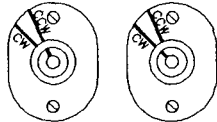

COUPLING ANGLE

UNIT NO.	CCW	CW
1A18-GV	0°	-
1A28-A	-	70°
2A14-A,GV	0°	70°
2A14-AW,GVW	-	70°
2A14-D	-	0°
2A18H-GV	-	70°
2A25-A	-	70°
2A28-A,GV	-	70°
2A64-GVW	-	70°
3A14-A,GV	0°	70°
3A14-D	-	0°
3A25-GV	0°	-
3A35-A	-	70°
3A64-A,GV	0°	70°
3A64-AM	-	45°
3A64-AW,GVW	-	70°
4A24-A,GV	0°	70°
4A24-AW,GVW	-	70°
4A24-D	-	0°
4A34-GVW	-	70°
5A24-GV	0°	-
6A24-D	-	0°
6A24-GV	0°	-
6A34-A,GV	0°	70°
6A34-AM	-	45°
6A34-AW,GVW	-	70°
6A34-GVC	-	70°
6I-2611	0°	-
9Y-6465	0°	-
109-8912	0°	-

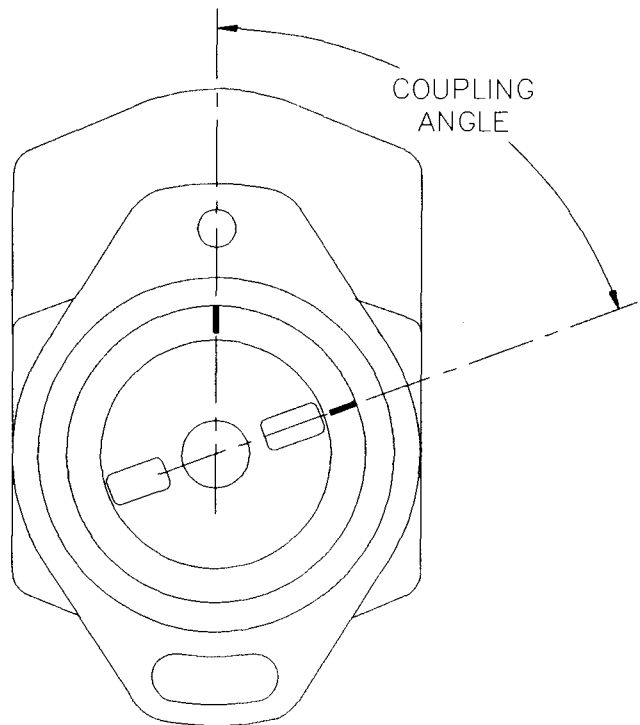

7.0 SERVICE - ASSEMBLY TOOLS

A. The following assembly tools are referred to in sections 5.3 and 6.4.

506 101A Press bearing-shaft (3) into housing (4)

506 101B Support housing (4)

506 102B Support shaft (3)

506 102C Press magnet-rotor assembly (7) on bearing-shaft (3)

506 103A Press bearing (31a) into cover housing (31)

506 103B Support cover housing (31) and bearing (31a)

506 104A Press shaft (31b) into bearing (31a)

506 104B Support bearing (31b)

8.0 OPERATIONAL TEST

A. Perform the tests following the guidelines of sections 3.0 through 3.3.

B. Run the Operating Test of section 3.2B. for one hour.

C. After the one hour Operating Test, check timing per section 3.3.