



Enhanced DE-2500 System Now Available

DE SERIES

Programmable Safety Shutdown, Monitoring and Control Products with Analog Input Capabilities

- A state-of-the-art family of products specifically designed to protect, monitor and control critical rotating machinery, such as engine or motor-driven compressors, pumps and generators.
- Two product choices to fit virtually any application.
- DE-2200 and 2500 models track operating hours and annunciate required service intervals of 11 different items.
- DE-2500 model automatically and continuously optimizes compressor efficiency and throughput via speed and capacity control feature and also incorporates automatic start capability.
- Features and benefits common to all models
 - Accept both analog and discrete inputs
 - Continuously monitor safety switches and analog set-points for correct operation, initiate alarm or shutdown if required, and provide alphanumeric display of cause or fault
 - Alphanumeric displays and process screens show four values simultaneously in both digital and bar-graph format
 - Capable of remote communication of operating condition, speed, operating hours, and process parameters via satellite, radio, cellular or telephone
 - Internal data log of 100 time-spaced “snap shots” of monitored data
 - Easily configurable via included Windows™-based terminal programs
 - Plug-in memory allows transfer of configuration information to a spare unit if necessary, eliminating the need for a PC and skilled technician in the field
 - Designed for harsh environments and wide temperature ranges
 - CSA-certified for use in Class I, Division 2, Groups C and D hazardous areas

The DE Series of products have been designed utilizing the latest state-of-the-art technology and surface-mount assembly techniques to provide users of compressors and other critical machinery with a sophisticated yet reliable means of protecting and controlling both the prime mover and load machine. The DE-2500 model is specifically designed to protect and control both reciprocating and screw compressors. Comprehensive communications between the DE device in the field and a central monitoring system further complement these capabilities.

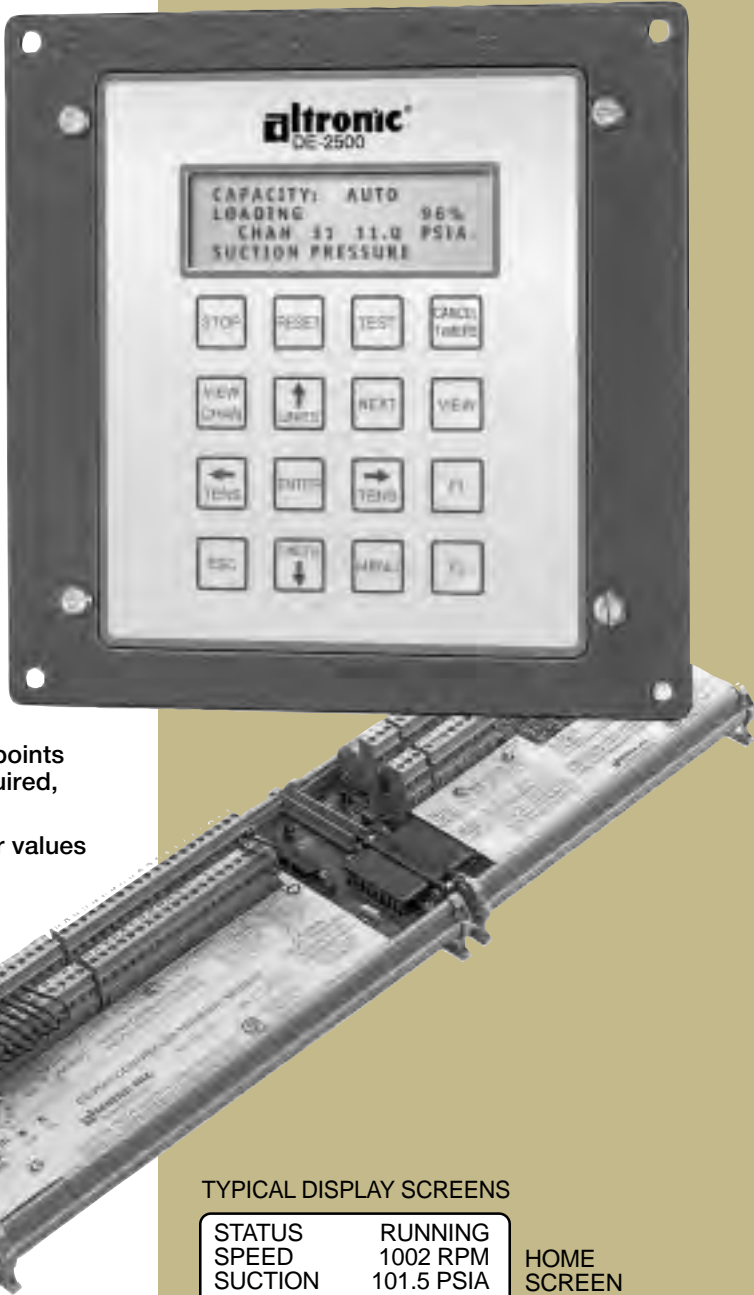

TYPICAL DISPLAY SCREENS

STATUS	RUNNING	HOME SCREEN
SPEED	1002 RPM	
SUCTION	101.5 PSIA	
DISCHARGE	300 PSIG	
Ps	SUCTION 600 PSI	PROCESS DIGITAL
Pi 1	INTSTG1 850 PSI	
Pi 2	INTSTG2 1100 PSI	
Pd	DISCHRG 1200 PSI	
SUCTION L		PROCESS BAR GRAPH
DISCHRG		
OIL TEMP L		
ENG MAN L		



CERTIFIED CLASS I, DIVISION 2, GROUPS C and D



DE-2200 OVERVIEW

Safety shutdown, monitoring, and communications

- “Panel-in-a-box” system is designed to offer complete prime mover and process monitoring and protection.
- Monitors up to thirty-one safety shutdown points (sixteen normally-open or normally-closed switches plus fifteen analog inputs, each of which has two setpoints). Any point can be configured for Class A, B, or C operation.
- System allows for direct connection of both thermocouples and transducers for temperature and process pressure monitoring, or for other process parameters.
- Communicates monitored parameters, fault status, and operating information via RS-232 or RS-485 in either Modbus RTU or ASCII protocols.
- Ideal retrofit package to update and add remote communication to existing field equipment.

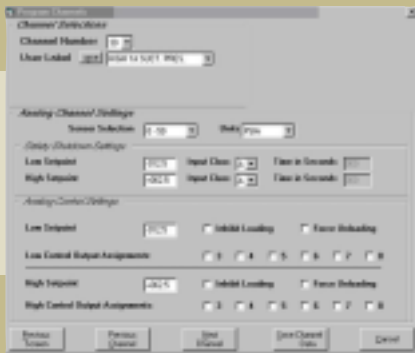

An easy to use, Windows™-based Terminal Program is included with each DE system for simple system configuration and remote monitoring.



DE-2500 OVERVIEW

Safety shutdown, monitoring, compressor throughput control, and communications

- Contains all of the features of the DE-2200 system described above plus auto-start and compressor throughput control capabilities.
- Integrated DE-2500 system is ideal for safety shutdown and control for both screw-style and reciprocating compressors.
- Reduces operating costs by continuously optimizing the compressor capacity for actual operating conditions.
- Incorporates two analog PID loops and one pulsed, digital PID loop to control the speed of the prime mover/compressor as well as to position the compressor capacity control valves (such as screw compressor slide valves).
- The second generation, DE-2500 system offers expanded PID control, differential pressure/temperature monitoring, direct thermocouple input monitoring, and improved program download speeds among many other new capabilities.
- Automatic load inhibit and/or forced unload to protect the controlled/monitored equipment from potentially destructive operation.
- Incorporates 12 digital outputs (4 solid-state relay, 8 discrete) for automatic start and/or auxiliary control functions.

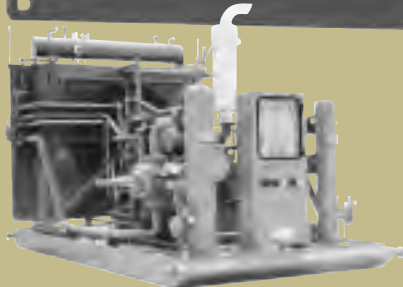

DE-2200 DESCRIPTION AND OPERATION

The CSA-certified DE-2200 system comprehensively protects critical rotating equipment such as reciprocating engines, pumps, and compressors, by continuously monitoring up to thirty-one points on the prime mover and/or the associated process. Each DE-2200 system can monitor up to sixteen normally-open or normally-closed switch contacts (typically from skid-mounted level or vibration switches) as well as up to fifteen analog inputs (of which up to seven can be used as inputs for J or K thermocouples). The system consists of a front panel-mounted Display Unit, and back panel, DIN-rail mounted Power Supply and Terminal Modules.

In the event of a fault, an alarm or shutdown is generated and its cause is displayed in plain language on the built-in 4 line by 20 character backlit LCD display. Depending upon system configuration, each point can be configured on fault to trip one of four digital outputs for shutdown or other control functions. Cause of fault, operating mode, speed, operating hours, and the value of all monitored analog inputs is continuously

available on the RS-232/485 serial port in either Modbus RTU or ASCII protocols. An easy-to-use Windows™-based Terminal Program is included with each DE-2200 system for configuration and monitoring.

Convenient serial access to the monitored data collected by the DE-2200 system expands the system's capabilities to include remote data acquisition. Monitored information can be relayed to personal computers or PLC's, or transmitted via telephone, cellular service, radio, or satellite monitoring and data transmission systems. A built-in data logging capability within the DE-2200 locally records up to 100 time-spaced data records containing all of the critical operating and analog input values (temperatures, pressures, etc.) in a rolling log format. This information has been found useful to many users whom either access the data locally or remotely for an analysis of events leading up to a shutdown.

DE-2500 DESCRIPTION AND OPERATION

The innovative, CSA-certified, DE-2500 system integrates all of the safety shutdown and monitoring functionality resident in the DE-2200 system with full system auto-start and compressor throughput (capacity) control. Designed to maximize the efficiency of the controlled compressor (screw or reciprocating), this full-featured system offers engine/compressor sequencing and load control, and can maintain peak compressor performance despite changes in ambient or field conditions. By operating the compressor continually at its most efficient point and at the required capacity, significant cost savings can be achieved.

The DE-2500's two analog PID loops, (as well as its digital pulsed outputs) used to control compressor slide or turn valves, act in concert to achieve a setpoint which is generally expressed as a desired suction, discharge, or manifold pressure. In typical operation, the DE-2500 system starts and warms-up the engine/compressor, raises it to load-carrying speed, then applies load by actuating the compressor slide valves or other capacity control devices. Should the control setpoint not be met at the minimum load carrying speed, the compressor speed is then automatically raised in an effort to meet the desired process pressure setpoint. This control strategy is governed by a number of user-adjustable load and speed limits which

can inhibit the application of additional load beyond what is deemed to be safe, can force the system to shed load, and can shutdown in the event that a maximum speed is exceeded.

The DE-2500 now features two operating modes: standard and enhanced. In the standard mode, all traditional DE-2500 capabilities are retained. When operating in the enhanced mode, significant new features and options are available to the user, including the ability to directly monitor J or K thermocouples, expanded customization controls for the control PID loops, the ability to implement on-board differential temperature and differential pressure monitoring, keyboard access to input point characteristics (class and lock-out time), and dramatically improved program download speeds. As is customary with Altronic products, full backward compatibility with the existing DE-2500 systems is assured.

Full RS-232/RS-485 Modbus and ASCII communications are supported in the DE-2500 system for use in conjunction with local and/or remote monitoring and control systems. An advanced, Windows™-based terminal program, combined with keypad access to many functions, allows for easy system setup.

DE-2200 SERIES SYSTEM DIAGRAM

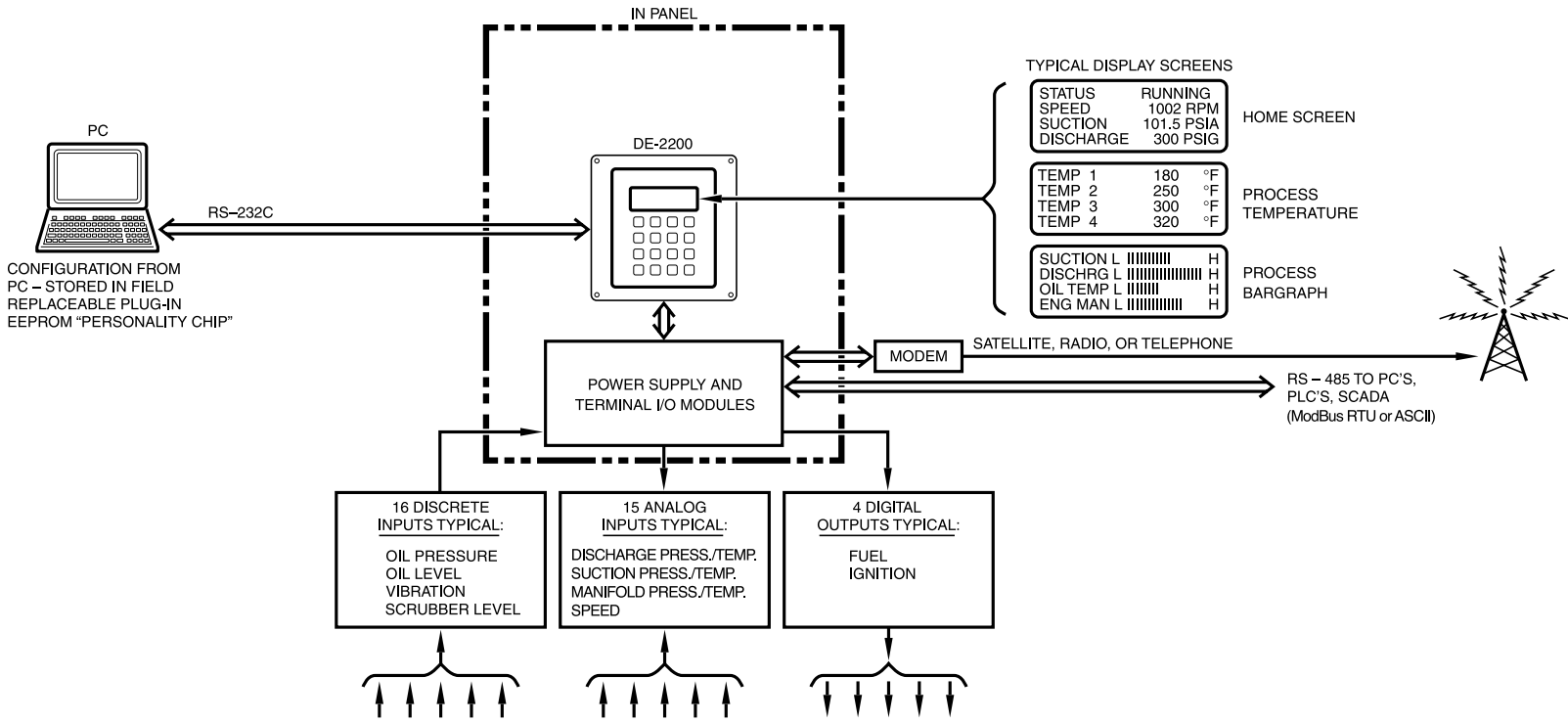

DE-2500 SERIES SYSTEM DIAGRAM

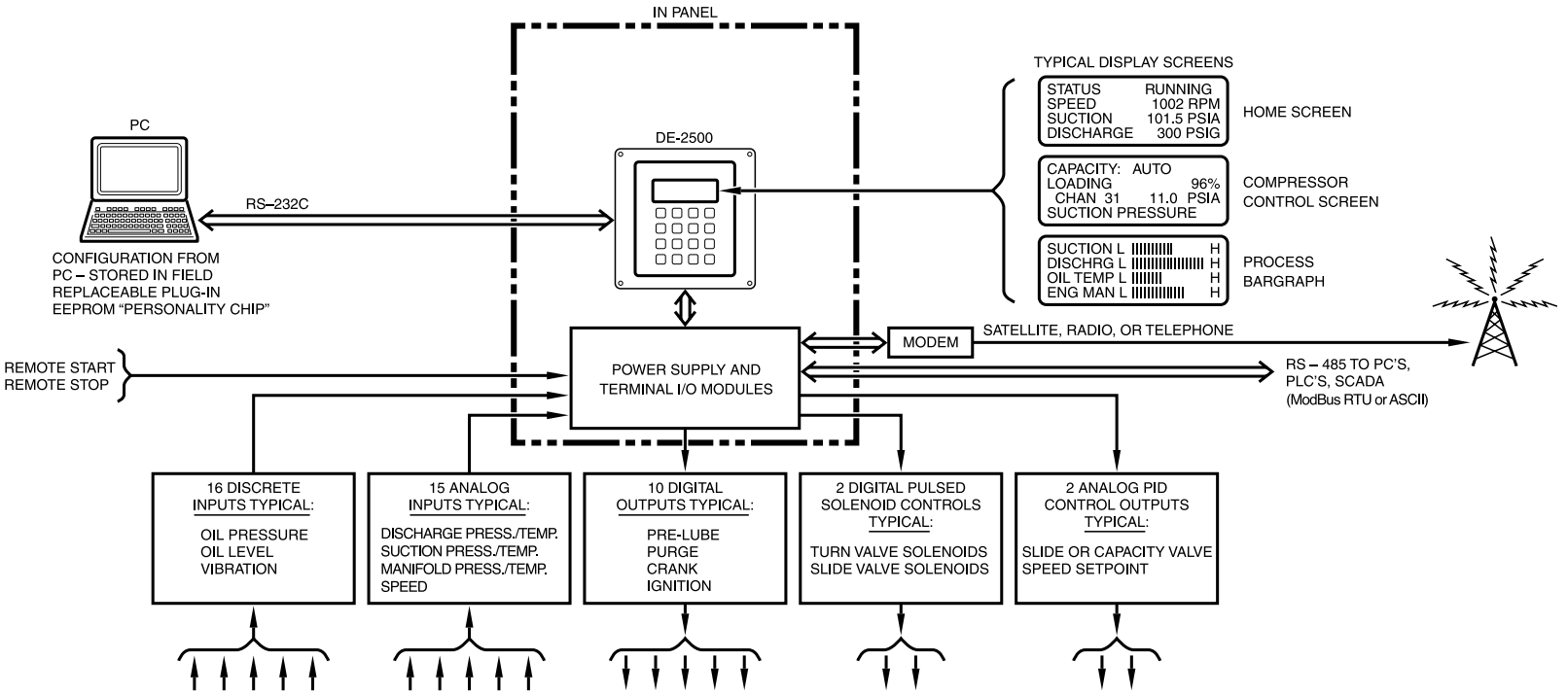

SUMMARY OF DE SERIES FEATURES AND SPECIFICATIONS

ITEM	DE-2200 SYSTEM	DE-2500 SYSTEM
SHARED FEATURES	Safety shutdown Local/remote communication 100 record data log Alphanumeric and bar-graph displays	
SPECIAL FEATURES	Pre/post lube control 11-item service meter	Auto-start/Compressor Control Logic 11-item service meter
DIGITAL INPUTS	16 switch contacts 1 remote stop (all are N.O. or N.C.)	16 switch contacts 1 remote start 1 remote stop (all are N.O. or N.C.)
DIGITAL OUTPUTS	4 solid state relays	4 solid state relays 6 digital switch (60V., 2A.) 2 pulsed switch (60V., 2A.)
ANALOG INPUTS	7 0-5 Vdc 7 0-5 Vdc or J-K TC 1 frequency	7 0-5 Vdc 7 0-5 Vdc or J-K TC 1 frequency
ANALOG OUTPUTS	None	2 4-20 mA PID loops
SERIAL PORTS	1 RS-232 and 2 RS-485	
DISPLAY	4 line x 20 character alphanumeric, backlit	
SCAN RATE	15 per second (analog channels on DE-2000 - 6 per sec.)	
AMBIENT TEMP.	-31°F to + 176°F / -35°C to +80°C	
POWER REQUIRED	12 to 24 Vdc, 15 watts maximum	
HAZARDOUS AREA CERTIFICATION	CSA Certified Class 1, Division 2, Groups C and D	

DE Series Data Logging and Communications

The DE Series products are designed to operate in a communication environment. The serial communications interfaces provide the user access to critical data, both locally and from remote locations, allowing predictive scheduled maintenance and/or dispatch of repair personnel with the correct parts. DE units can also initiate a call-out in the event of a fault. ModBus and ASCII protocols are supported in both models.

At the core of the DE Series communications functions are the data logs (see table at right). These snapshots of data are taken at user-defined intervals, and are a compilation of the analog values being monitored by the DE, plus unit speed, status, and complete information on the first fault that caused a system shutdown (identity, value, date, time). Using the Terminal Program, data log information can be downloaded locally to a portable PC or communicated remotely via telephone, satellite or radio. Altronic's CompressorWatch.com system couples satellite or cellular technology with Web-based reporting, e-mail and paging to give users access to critical data no matter where they or the reporting equipment are located.

An integral data analysis/trending package that is included with the DE Terminal Software can display and graph this data for inspection and analysis. The sample graph shown at right depicts a shutdown that was caused by compressor discharge temperature exceeding its 325° setpoint, followed by a restart.

SAMPLE DATA LOG AND GRAPH

COMP. STATION #01 GIRARD, OHIO	User entered data log header describing location
001 10333 HRS	Record number and running hours
10-19-1998 9:46 AM	Date/time the record information was collected
STATUS RUNNING	Normal home screen status line
SPEED 925 RPM	Normal home screen, line two
SUCTION 102.3 PSIA	Normal home screen, line three
DISCHARGE 300 PSIG	Normal home screen, line four
PRESS 1 102.3 PSIG	First view process screen, line one
PRESS 2 355 PSIG	First view process screen, line two
PRESS 3 250 PSIG	First view process screen, line three
PRESS 4 275 PSIG	First view process screen, line four
TEMP 1 55 EF	Second view process screen, line one
TEMP 1 170 EF	Second view process screen, line two
TEMP 1 180 EF	Second view process screen, line three
TEMP 1 190 EF	Second view process screen, line four
TEMP 1 220 EF	Third view process screen, line one (enhanced 2500)
PRESS 5 22 PSIA	Third view process screen, line two (enhanced 2500)
USER LABEL	Third view process screen, line three (enhanced 2500)
USER LABEL	Third view process screen, line four (enhanced 2500)
1ST FAULT HIGH	First fault indication when fault occurs
CHAN A3 500 PSI	Channel number and value of first fault
HIGH INTERSTAGE PRESS	20 character label associated with the first fault
10-19-1998 9:46 AM	Date and time of the first fault

* If a view process screen line is not programmed in the controller, the line will be blank.
 ** These lines will be blank when there are no faults.

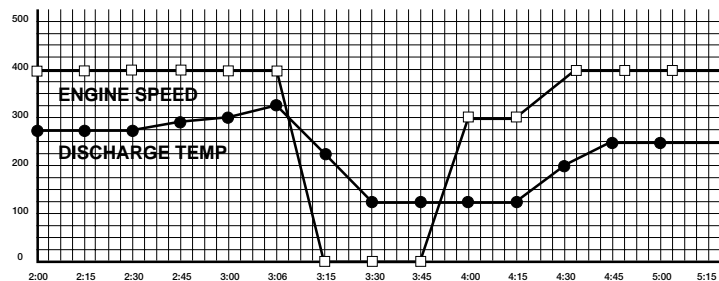

DIMENSIONS (DE-2500 shown)

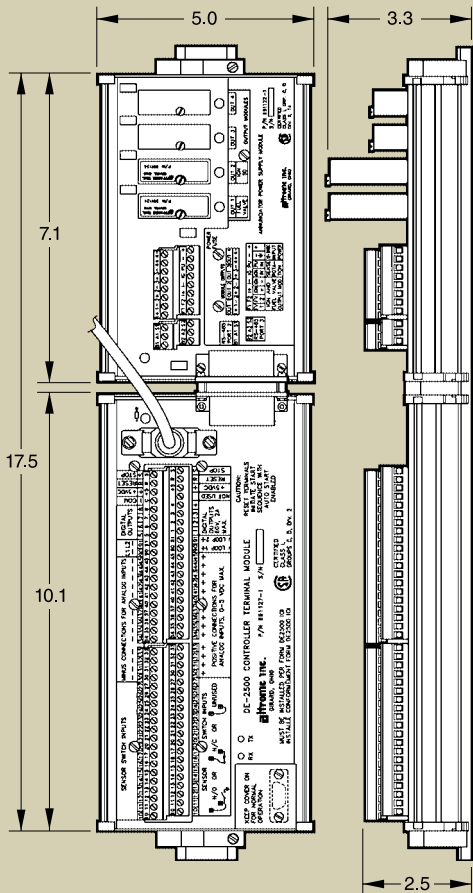
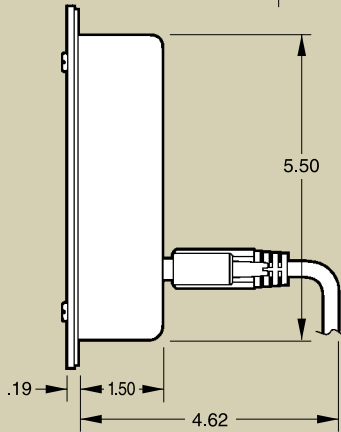
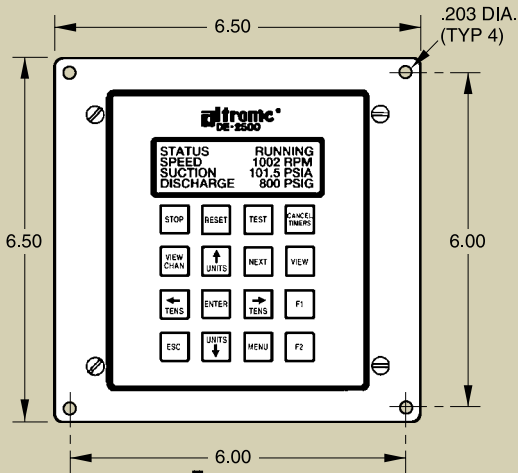

TO ORDER

DISPLAY MODULE

DE-2200 system	DE-2200
DE-2500 system	DE-2500

POWER SUPPLY MODULE

All DE systems	691122-1
----------------------	----------

TERMINAL MODULE

DE-2200 system	691136-1
DE-2500 system	691127-1

CABLE ASSEMBLIES (common to all DE systems)

Display to Terminal Module (DB-25)	693115-1
Power Supply to Terminal Module (DB-25)	693115-1*
Display Module RS-232 Port (DB-9)	693116-1

*Use only if Power Supply and Terminal Modules are mounted separately.

OUTPUT RELAY MODULES (common to all DE systems)

C.D. Fuel Valve/Ignition	691124
5-48 Vdc, 5.0 A.	691125
5-60 Vdc, 2.0 A.	691056
5-200 Vdc, 0.67 A.	691066
24-280 Vac, 2.0 A.	691065

AVAILABLE ALTRONIC TRANSDUCERS

PRESSURE TRANSDUCERS

0-50 psia	691204-50
0-100 psia	691204-100
0-300 psia	691204-300
0-500 psia	691204-500
0-100 psig/0-680 Kpa	691201-100
0-300 psig/0-2040 Kpa	691201-300
0-500 psig/0-3400 Kpa	691201-500
0-1000 psig/0-6800 Kpa	691201-1000
0-2000 psig/0-136 bar	691201-2000
0-5000 psig/0-340 bar	691201-5000

TEMPERATURE TRANSDUCERS

Range: +5° F to 350° F / -15° C to 176° C (±3° F / ±2° C)	
1.75" length	691202-300
5.75" length	691203-300
Range: -40° F to 450° F / -40° C to 232° C (±6° F / ±4° C)	
1.75" length	691212-450
5.75" length	691213-450

TRANSDUCER CABLES

5 ft. length	693008-5
25 ft. length	693008-25
50 ft. length	693008-50

altronic[®]
inc.

712 TRUMBULL AVE. / GIRARD, OHIO 44420
PHONE: (330) 545-9768 / FAX: (330) 545-9005
Email: sales@altronicinc.com / Web: www.altronicinc.com