

SERVICE INSTRUCTIONS

FORM CPU-95 SI 4-08



WARNING:

PROPER INSTALLATION, MAINTENANCE, REPAIR AND OPERATION OF THIS EQUIPMENT IS ESSENTIAL. THE RECOMMENDED PRACTICES CONTAINED HEREIN SHOULD BE FOLLOWED WITHOUT DEVIATION. AN IMPROPERLY INSTALLED OR OPERATING IGNITION SYSTEM COULD CAUSE PERSONAL INJURY TO OPERATORS OR OTHER NEARBY PERSONNEL.

TABLE OF CONTENTS

SECTION	ITEM	PAGE
1.0	SYSTEM DESCRIPTION	2
2.0	PARTS IDENTIFICATION AND SPECIFICATION	5
2.1	CPU-95 Ignition Module	5
2.2	CPU-95 Display Module	7
3.0	TEST STAND REQUIREMENTS	8
4.0	TESTING PROCEDURE - CPU-95 IGNITION MODULE	10
4.1	Voltage Output Test	10
4.2	Operational Tests	10
4.3	Timing Tests	11
5.0	OHMMETER CHECKS	11
5.1	Ignition Module Power Board	11
6.0	OSCILLOSCOPETESTS	11
6.1	Test Set-Up	11
6.2	Storage Capacitor Voltage Pattern	11
6.3	Multi-Strike Tests	11
7.0	TESTING PROCEDURE - DISPLAY MODULE	12
7.1	Operational Tests	12
8.0	TROUBLESHOOTING	13
8.1	Ignition Module	13
8.2	Display Module	13
9.0	BOARD REPLACEMENT PROCEDURE - IGNITION MODULE LOGIC BOARD	14
9.1	Disassembly Procedure	14
9.2	Assembly Procedure	14
10.0	BOARD REPLACEMENT PROCEDURE - IGNITION MODULE POWER BOARD	14
10.1	Disassembly Procedure	14
10.2	Assembly Procedure	14
11.0	BOARD REPLACEMENT PROCEDURE - DISPLAY MODULE DISPLAY BOARD	15
11.1	Disassembly Procedure	15
11.2	Assembly Procedure	15



CPU-95 DIGITAL IGNITION SYSTEM

1.0 SYSTEM DESCRIPTION

1.1 The Altronic **CPU-95**, DC-powered ignition system is a microprocessor-based capacitor discharge system designed for application on natural gas fueled engines. The system features crankshaft-triggered timing accuracy and the capability to vary timing electronically by several means, including an external **4-20 mA** control signal connected to the optional Display Module. The system is field-programmable and offers a variety of advanced control methods, emissions reduction, primary and secondary spark diagnostics, self diagnostics, serial communications and engine protection features.

1.2 The **CPU-95** ignition system consists of two main parts: an optional user interface Display Module and an engine mounted Ignition Module (**SEE FIGURE 1**). The optional Display Module has an alphanumeric back-lit LCD display that shows the operating status, engine RPM, energy level, single or double-striking mode, current loop input value, ignition timing, set-up, and diagnostic information. The Display Module is a means of monitoring or changing monitored parameters, all of the ignition system functions are performed in the Ignition Module. Five models of the Ignition Module are available:

791950-8	8-outputs, single storage capacitor
791950-16	16-outputs, single storage capacitor
791950-18	18-outputs, single storage capacitor
791952-18	18-outputs, dual storage capacitors
791958-16	16-outputs, single storage capacitor (VariSpark®)

1.3 Timing changes on the **CPU-95** are derived by counting pulses from the reference teeth. The timing change increment is dependent on the number of holes or teeth being sensed. The minimum timing change is defined as follows (**where N = number of holes or teeth**):

If $N < 270$, then increment = $45/N$ degrees.

If $N > 270$, then increment = $90/N$ degrees.

1.4 Power requirement is **24 Vdc, 5 amperes** nominal for typical applications (**10 amperes** for systems using the **791958-16** Ignition Module). **REFER TO FORM CPU-95 II, SECTION 9.2.**

FIGURE 1 - SYSTEM OVERVIEW

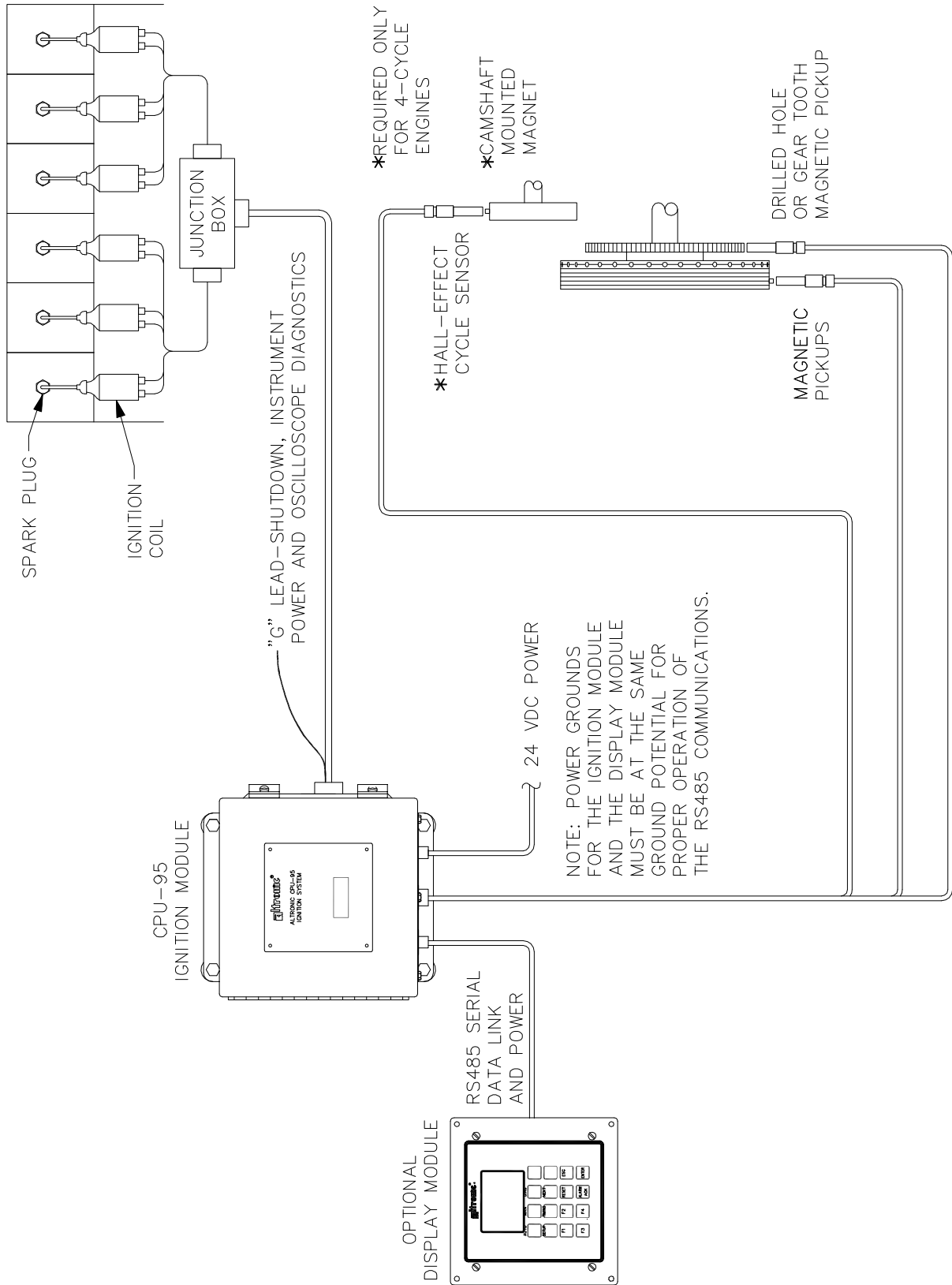

CPU-95 DIGITAL IGNITION SYSTEM

FIGURE 2 - PARTS IDENTIFICATION

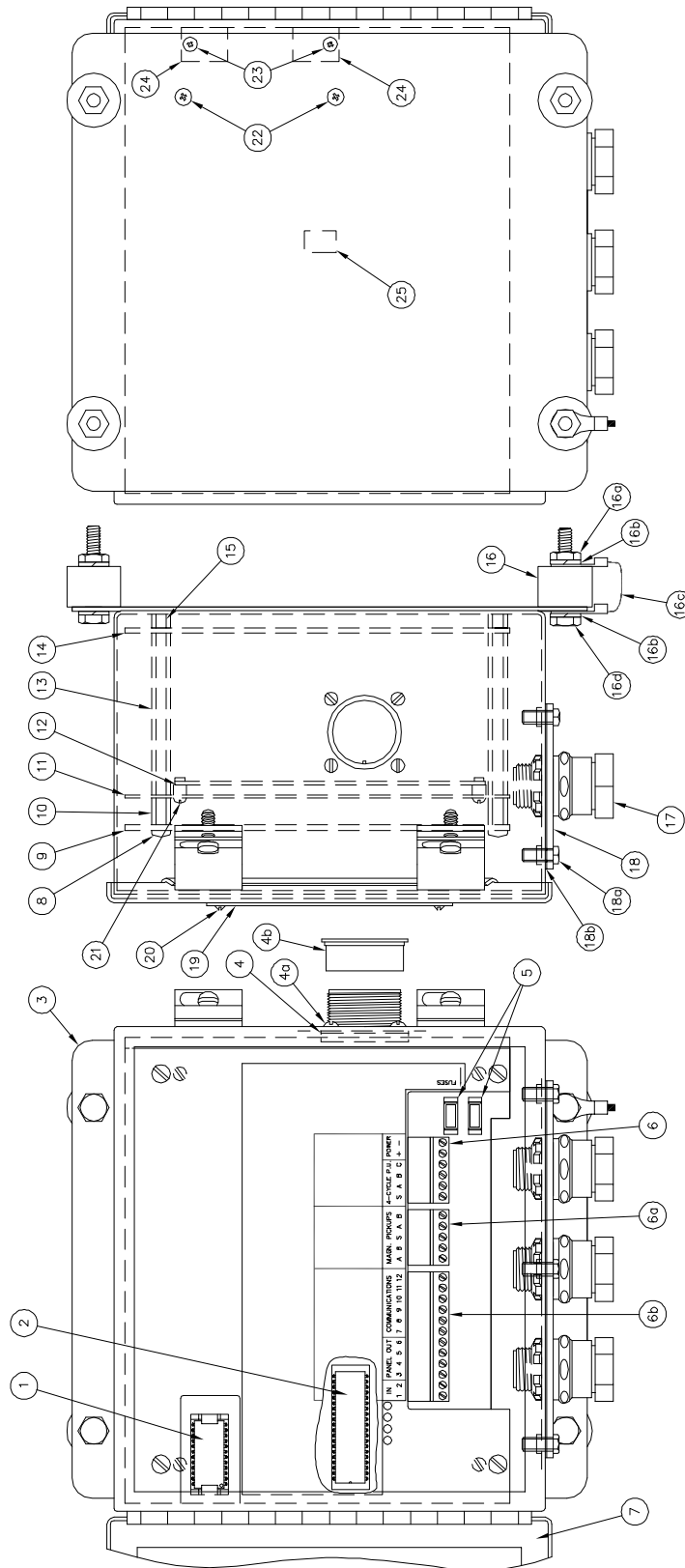

2.0 PARTS IDENTIFICATION AND SPECIFICATION

2.1 PARTS LIST - IGNITION MODULE 791950-8,-16,-18; 791952-18; 791958-16

SEE FIGURE 2

FIGURE & REFERENCE NO.	QUANTITY	PART NO.	DESCRIPTION
2-1	1	601668-A	EEprom, blank
-2	1	601780-16	Microprocessor, 791950-8,-16 unit
		601780-18	Microprocessor, 791950-18 unit
		601825-18	Microprocessor, 791952-18 unit
		601965-16	Microprocessor, 791958-16 unit
-3	1	710121	Enclosure
-4	1	501222	Gasket, connector
-4a	4	902648	Screw 6-32
-4b	1	510517	Cap, connector
-5	2	601871	Fuse 15A
-6	1	204015	Plug, 6-pin
-6a	1	204016	Plug, 5-pin
-6b	1	204014	Plug, 12-position
-7	1	610674	Gasket, lid
-8	4	902439	Screw 10-32
-9	1	772065-1	Logic cover board
-10	4	610662	Standoff
-11	1	772059-1	Logic board assembly
-12	1	772064-1	Logic shield board
-13	4	610676	Standoff
-14	1	781059-8	Power board assembly, 791950-8 unit
		781059-16	Power board assembly, 791950-16 unit
		781059-18	Power board assembly, 791950-18 unit
		781067-18	Power board assembly, 791952-18 unit
		781084-16	Power board assembly, 791958-16 unit
-15	4	710015	Standoff, nylon
-16	4	610165	Shock mount
-16a	4	902469	Nut 5/16-18
-16b	8	901010	Lockwasher 5/16
-16c	1	610386	Ground strap
-16d	4	902593	Bolt 5/16-18
-17	3	510527	Conduit fitting
-18	1	210622	Bottom plate
-18a	6	902599	Screw 10-24
-18b	1	210625	Gasket, plate
-19	1	702120A	Label
-20	4	902578	Screw 4-40
-21	4	902061	Screw 6-32
-22	2	902615	Screw 8-32
-23	2	902640	Screw 6-32
-24	2	610636	Insulator, T-MOS
-25	1	610530	Insulator, voltage regulator

CPU-95 DIGITAL IGNITION SYSTEM

FIGURE 3 – PARTS IDENTIFICATION

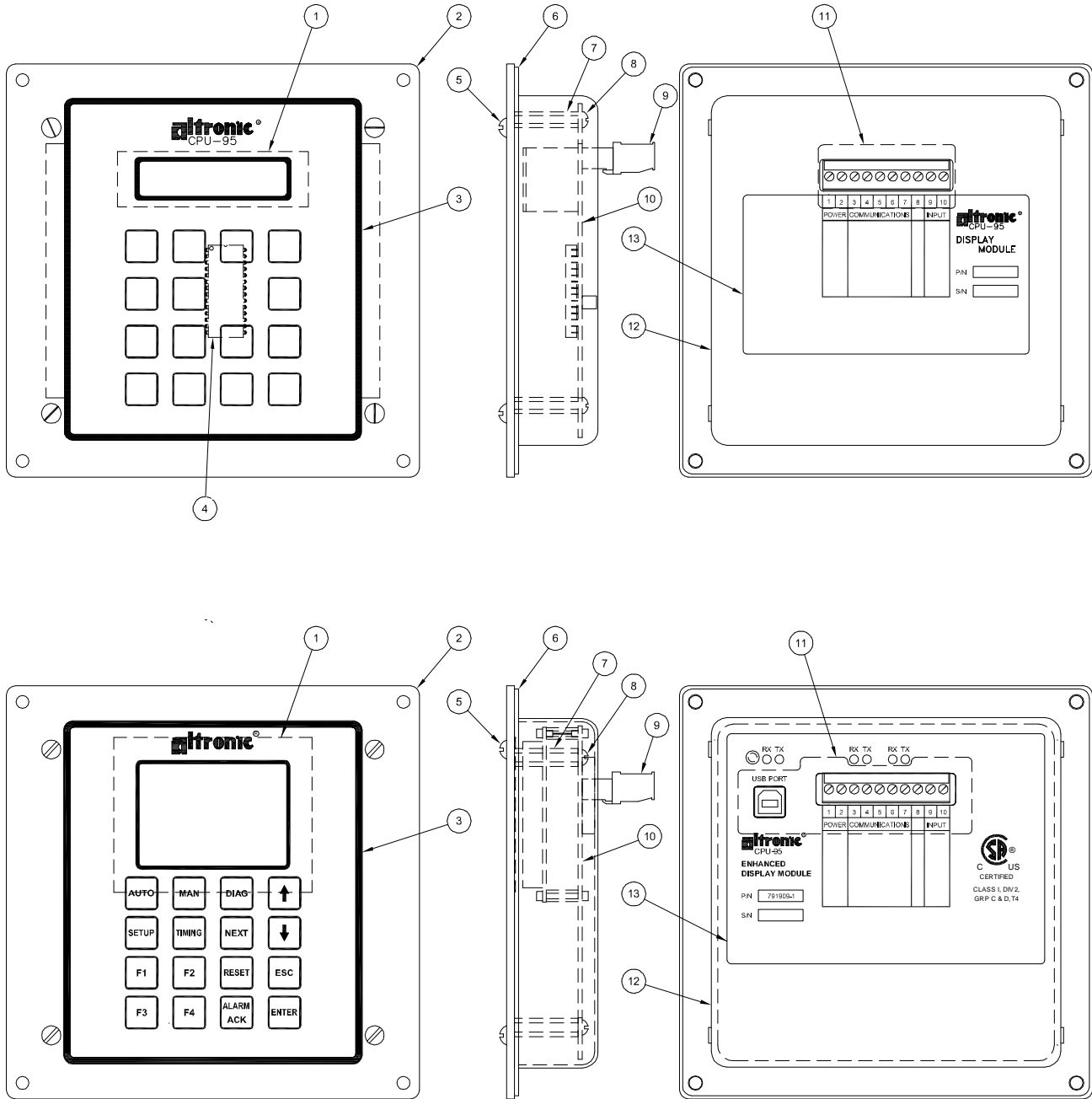

2.2 PARTS LIST - CPU-95 DISPLAY MODULE 791902-x; 791908-1

SEE FIGURE 3

FIGURE & REFERENCE NO.	QUANTITY	PART NO.	DESCRIPTION
3-1	1	602415	Spacer
-2	1	710133	Front cover
-3	1	710124	Keypad
-4	1	601771	EPROM, 791902-1
		601771-S1	EPROM, 791902-1S
		601771-S2	EPROM, 791902-4
		601876	EPROM, 791902-3
		601971-1	EPROM, 791908-1
-5	4	902590	Screw 8-32
-6	1	610325	Gasket, front cover
-7	3	610677	Standoff
-8	3	902560	Screw 6-32
-9	1	604162	Terminal block
-10	1	772056-1	Display board assembly, 791902-1
		772056-1S	Display board assembly, 791902-1S
		772056-4	Display board assembly, 791902-3
		772056-5	Display board assembly, 791902-4
		772095-1	Display board assembly, 791908-1
-11	1	710125	Gasket, back enclosure
-12	1	710134	Back enclosure
-13	1	702122-1A	Back label, 791902-1,-1S,-3,-4
		702181-1A	Back label, 791908-1

2.3 PARTS LIST - CPU-95 ENHANCED DISPLAY MODULE 791909-1

FIGURE & REFERENCE NO.	QUANTITY	PART NO.	DESCRIPTION
3-1	1	710266	Spacer
-2	1	710261	Front cover
-3	1	710264	Keypad
-4	N/A		
-5	4	902590	Screw 8-32
-6	1	610325	Gasket, front cover
-7	4	610677	Standoff
-8	4	902560	Screw 6-32
-9	1	604162	Terminal block
-10	1	772116-1	Display board assembly
-11	1	710265-1	Gasket, back enclosure
-12	1	710263-1	Back enclosure
-13	1	702201-1	Back label

CPU-95 DIGITAL IGNITION SYSTEM

3.0 TEST STAND REQUIREMENTS

3.1 In order to test an Altronic CPU-95 ignition system, a special test stand is required. The basic test stand is similar to that required for the Altronic CPU-90 system.

3.2 The following items are required to test the Altronic CPU-95 system:

- A. A variable speed motor of 0.5 HP or greater, capable of rotating 1800 RPM with a standard ignition drive accepting either flange or base mounting.
- B. A spark degree wheel graduated in 360 increments with the indicator attached to the shaft common to the standard ignition drive.
- C. Sixteen (16) 501061 ignition coils connected to suitable, adjustable spark gaps. **NOTE: THE TEST STAND SHOULD INCORPORATE EIGHTEEN (18) IGNITION COILS IF 18-OUTPUT UNITS WILL BE TESTED.**
- D. A source of gear tooth pulses mechanically connected to the ignition drive; a 180-tooth gear is recommended.
- E. A single reset pin (6-32 steel machine screw recommended) mounted to the face of the gear.
- F. Magnetic pickups (691118-x) mounted to sense the gear teeth and the reset pin.
- G. A primary wiring harness connecting the ignition coils to the CPU-95 Ignition Module. This requires connector MS3108A-22-14S, Altronic part number 504056. **NOTE: THE HARNESS IS WIRED DIFFERENTLY FOR 18-OUTPUT UNITS.**
- H. A 581602 manual control loop unit to simulate the 4-20mA control signal.
- I. A DC power source capable of supplying 24Vdc, 5 amps (see Installation Instructions form CPU-95 II, section 9.2 and drawing 709 961).
- J. An Altronic II-CPU Alternator; part no. 290213H is recommended. A distributor shaft assembly with 2:1 gear installed is required to test a 4-cycle application. The rotating magnet on the distributor shaft assembly must be over the Hall-effect switch when the reset pin on the test stand is opposite its magnetic pickup.
- K. An Altronic II-CPU back cover assembly 281500-1 or -2 and mating harness 293024-1. Connect the wiring harness as shown on the following page.
- L. A blank CPU-95 EEPROM, Altronic part number 601668-A. Test memories can be used if the Terminal Program is not used. Test memories for 16 and 18-cylinder, 4-cycle applications programmed with the number of teeth used on the test stand (usually 180) will be needed.
- M. Altronic CPU-95 Terminal Program part number CPU-95.MEM. **NOTE: REFERENCE FORM CPU-95 PI, SECTION 1.3 FOR COMPUTER AND PERIPHERAL REQUIREMENTS FOR THE TERMINAL PROGRAM.**
- N. A means to elevate the CPU-95 Ignition Module to a controlled temperature of 150°F (65°C).
- O. Altronic Test Unit 791025-1 can provide simulated pickup signals to exercise the CPU-95 outputs at a fixed firing rate.
- P. CPU-95 Display Module 791902-1 can be connected using a 4-conductor cable 503194 as shown in the Test Stand Wiring diagram. **NOTE: SUPPLY POWER TO THE DISPLAY MODULE BY CONNECTING TWO OF THE FOUR CONDUCTORS TO THE CPU-95 INPUT POWER TERMINALS. IF A SEPARATE SUPPLY IS USED TO POWER THE DISPLAY, THE GROUNDS MUST BE AT THE SAME POTENTIAL FOR PROPER OPERATION OF THE RS485 COMMUNICATIONS.**

FIGURE 4 – TEST STAND WIRING

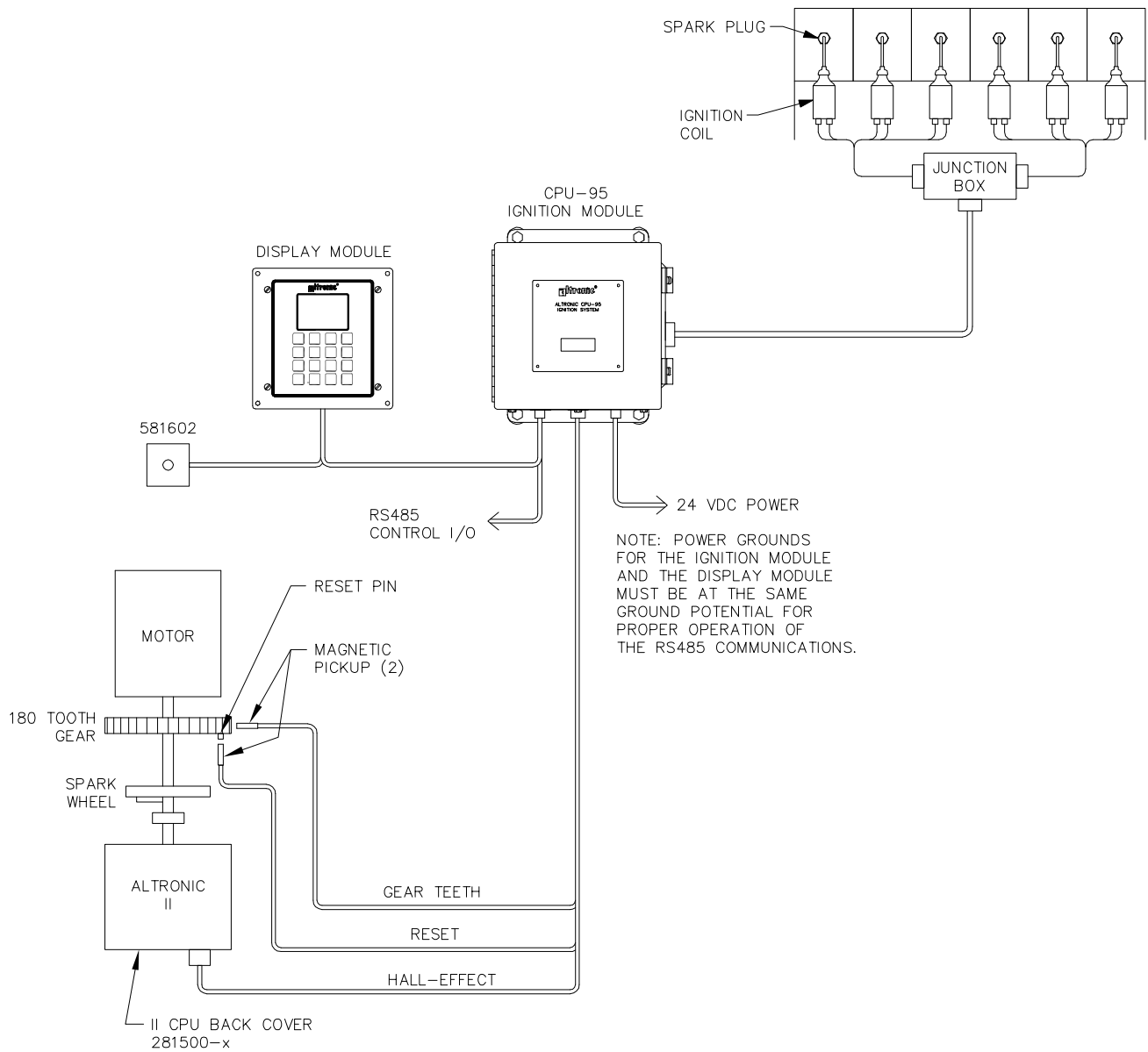

4-CYCLE PICKUP INPUT WIRING

CPU-95 INPUT	281500-X 5-PIN CONNECTOR	DESCRIPTION
A (4-cycle pickup)	PIN E	HALL EFFECT SWITCH (+)
B (4-cycle pickup)	PIN D	HALL EFFECT SUPPLY (+)
C (4-cycle pickup)	PIN C	HALL EFFECT COMMON (-)
	PIN B	*SEE NOTE 1
	PIN A	*SEE NOTE 1

*Note 1: Connect leads A and B together (shorts the alternator output).

CPU-95 DIGITAL IGNITION SYSTEM

4.0 TESTING PROCEDURE - CPU-95 IGNITION MODULE

4.1 VOLTAGE OUTPUT TEST: Using a known good Display Module, connect CPU-95 unit to test stand. **REFERENCE FORM CPU-95 II FOR CORRECT WIRING OF UNIT AND CPU-95 OI FOR OPERATION OF UNIT.** Set the Ignition Module for energy level 2 (E2). Operate the test stand at 300 RPM leaving the 19-pin output connector disconnected. Output voltage is measured from the G pin (+) to the J pin (-). The output voltage should be 160 ±10 Vdc.

4.2 OPERATIONAL TESTS: With the system completely connected, perform the following tests on the Ignition Module. It is recommended that these tests be performed with the Ignition Module heated to a temperature of 150°F (65°C). The tests should be performed using a test EEPROM having the same number of teeth as the test stand, or program a blank EEPROM.

NOTE: This test is only valid with 8 and 16 output Ignition Modules; there is no connection to the storage capacitor in 18-output units.

NOTE: Do not program over the original EEPROM. A P4A180.FC pattern is recommended for a 16-output unit and a R4V180.FC pattern for an 18-output unit, assuming the test stand uses a 180 tooth gear.

180 TOOTH GEAR RPM	TEST
75 RPM	All outputs fire a 15mm gap.
600 RPM	All outputs fire a 15mm gap.
1200 RPM	All outputs fire a 15mm gap.
1200 RPM	Each output fires consistently in sequence; timing as follows starting with output "A" and proceeding in alphabetical sequence: 8 - OUTPUT: A - B - C - D - E - F - K - L H4A180.FC 0-90-180-270-0-90-180-270 16 - OUTPUT: A - B - C - D - E - F - K - L - M - N - P - R - S - T - U - V P4A180.FC 0-45-90-135-180-225-270-315-0-45-90-135-180-225-270-315 18 - OUTPUT: A - B - C - D - E - F - G - H - K - L - M - N - P - R - S - T - U - V R4V180.FC 0-50-80-130-160-210-240-290-320-0-50-80-130-160-210-240-290-320 NOTE: Perform remaining tests B. through G. at 1200 rpm.

B. The Display Module should read "FIRING". The panel I/O switches should be as follows:

Alarm Out - closed; Fault Out - closed; Fire Confirm Out - closed.

C. The four internal LED's on the logic board should be as follows:

Power - on; Rx - flashing; Tx - flashing; Alarm - off.

D. Verify "cylinder spark data" number reads in accordance with form CPU-95 OI, SECTION 11.4.

E. Verify "cylinder spark data" number reacts in accordance with form CPU-95 OI, SECTION 11.3.

When the diagnostic flag is set the alarm out I/O switch on the panel should open and the Display Module should read "WARNING VIEW DIAGNOSTICS". Verify that the proper warning and output identifier was captured (press DIAG key on Display Module).

F. Ground the shutdown lead "G" (8 and 16 output units only). Ignition firings should immediately cease and the display should read "SHUTDOWN". The panel I/O switches should be as follows:

Alarm Out - closed; Fault Out - closed; Fire Confirm Out - open.

G. Ground the Shutdown Input (all units). Ignition firings should immediately cease and the display should read "SHUTDOWN". The panel I/O switches should be as follows:

Alarm Out - closed; Fault Out - closed; Fire Confirm Out - open.

SEE FORM CPU-95 OI, SECTIONS 5.0 AND 6.0

- 4.3 TIMING TESTS:** The following tests should be performed on the Ignition Module to verify proper control of timing. Use a test Display Module.
- A. Enter the TIMING menu and test the GLOBAL RETARD. Vary the global timing and verify the timing changes on the spark wheel and on the Display Module (SEE FORM CPU-95 OI SECTION 5.0).
 - B. Enter the TIMING menu and test the ONE-STEP RETARD. Ground the miscellaneous input and assure the timing retards by the one-step retard value (SEE CPU-95 OI SECTION 6.4).
 - C. Enable CURRENT LOOP RETARD and test the 4-20mA CURRENT LOOP. Vary the input current by adjusting the 581602 connected to the Display Module and assure the timing changes in accordance with the unit's programmed curve (SEE CPU-95 OI SECTION 6.2).

5.0 OHMMETER CHECKS

SEE SECTION 6.0

- 5.1 IGNITION MODULE POWER BOARD:** The following tests should be made using a Simpson Model 260 analog volt-ohmmeter (VOM) set to "ohms". The ohmmeter scale should be set to R x 10,000. Readings outside the range indicated establish a defective Power Board. A Power Board passing the ohmmeter tests may still be defective and the full test should be performed using an oscilloscope to confirm correct operation.
- A. Check the resistance with the positive lead of the ohmmeter connected to the "G" lead and the negative lead connected to each output pin of the output connector. If ohmmeter reading is less than 250,000 ohms replace Power Board (2-14).
 - B. Check the resistance with the negative lead of the ohmmeter connected to the "G" lead and the positive lead connected to each output pin of the output connector. If ohmmeter reading is less than 250,000 ohms replace Power Board (2-14).
- NOTE: THE "J" LEAD IS NOT AN OUTPUT PIN.**

6.0 OSCILLOSCOPE TESTS

- 6.1 TEST SET-UP:** Two 100:1 oscilloscope probes are required. Test speed is 1000 RPM.
- 6.2 STORAGE CAPACITOR VOLTAGE PATTERN (8 and 16 output units only)**
- A. Connect the trigger input of the oscilloscope to the "A" primary coil lead.
NOTE: This is a 140 to 180 volt, positive polarity signal.
 - B. Connect the oscilloscope reading probe to the "G" lead to view all outputs.
SEE NORMAL PATTERN ON NEXT PAGE.
 - C. Verify peak output voltage is:
140±10 volts for energy level E1
160±10 volts for energy level E2
180±10 volts for energy level E3
- 6.3 MULTI-STRIKE TESTS (791950 and 791958 series only)**
- A. Set Unit to MULTI-STRIKE mode via Display Module keypad.
 - B. Verify timing of all outputs using the table in section 4.2 A.
791950 Series: Verify all outputs have two firings. The separation will vary with rpm and should equal 7 degrees at 1000 rpm. The second firing is automatically turned off above 1050 rpm.
791958 Series: Verify a longer duration spark on the degree wheel compared to normal mode.
 - C. 8 and 16 Output Units Only: Connect oscilloscope to the "G" lead and view pattern. Discharge waveform should appear as shown on the next page.

CPU-95 DIGITAL IGNITION SYSTEM

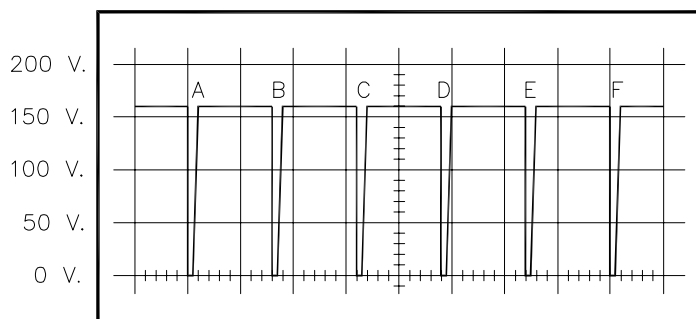

NORMAL PATTERN (ALL UNITS)

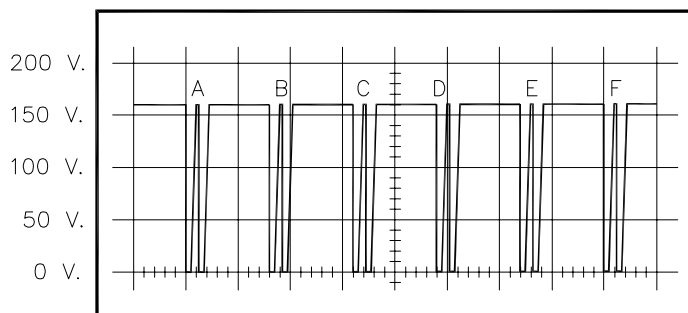

MULTISTRIKE PATTERN (791950-X)

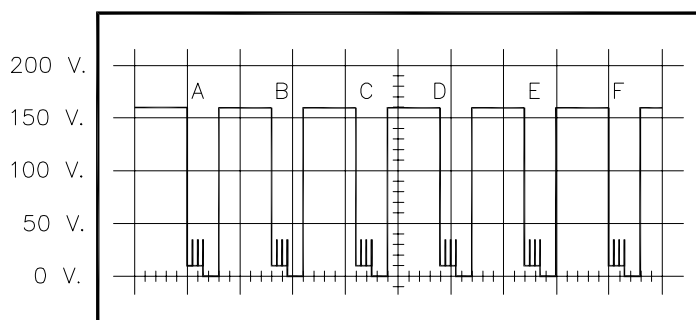

VARISPARK PATTERN (791958-X)

7.0 TESTING PROCEDURE - DISPLAY MODULE

7.1 OPERATIONAL TESTS: Connect the Display Module to a test Ignition Module known to be operational.

- Apply 24Vdc input power to both units and verify Display Module communicates with Ignition Module. Display should read "READY".
- Hold down ENTER key for approximately six seconds to access keypad test, depress each key and verify that a unique number (0-15) is identified for each key.
- Start rotation of test stand motor and increase speed to 300 RPM. Display should read "FIRING". With spark wheel turned on and firing output "A" at zero degrees, verify current loop operates as programmed and that Display Module shows the correct loop value (4-20mA).
- Ground miscellaneous input on Display Module and verify ONE-STEP timing retards the amount stored in the ONE-STEP timing value.

SEE INSTALLATION INSTRUCTIONS FORM CPU-95 II FOR CORRECT WIRING AND OPERATING INSTRUCTIONS FORM CPU-95 OI FOR OPERATION OF THE DISPLAY MODULE.

NOTE: Ground only the miscellaneous input on Display Module and not on Ignition Module.

8.0 TROUBLESHOOTING

Perform all tests at a test stand speed of **1000 RPM** with a **4-cycle** test memory. The following tests assume an adequate **24 Vdc** power source and properly installed magnetic and Hall-effect pickups.

8.1 IGNITION MODULE: The following tests are to be performed with a known good Display Module.

PROBLEM	TEST	TEST INDICATION	CORRECTIVE ACTION (Fig. 2)
No output	Section 4.1	No voltage	Replace power board (14)*
No output	Section 4.1	Low voltage	Replace power board (14)
One output does not fire	Section 4.2/6.2	Missing discharge on stand or scope	Replace power board (14)
Only one output fires	Section 4.2/6.2	Only one spark gap is firing	Replace power board (14)
No Multi-Strike function	Section 6.3	Outputs do not have second firing	Measure voltage from pin 4 to Vss of large ribbon cable on logic board. If voltage is 5V. in Multi-Strike mode, replace power board (14). If voltage is 4V. or less and Display Module shows Multi-Strike identifier, replace logic board (11)
Panel I/O switches malfunction	Section 4.2 B, C	Does not function as described	Replace logic board (11)
Incorrect or missing "cylinder spark data"	Section 4.2 D, E	Sets non-existent WARNINGS on display, always reads 0 or 255	Replace power board (14)*
Unit does not acknowledge SHUTDOWN	Section 4.2 F, G	Unit continues to fire	Fails section 4.2 F, replace power board (14) Fails section 4.2 G, replace logic board (11)
Timing varies	Section 4.2 A	Timing other than as shown	Replace logic board (11)
Timing control malfunctions	Section 4.3	Timing does not change or changes incorrectly	Replace logic board (11)

* May indicate a defective power or logic board.

8.2 DISPLAY MODULE: The following tests are to be performed with a known good Ignition Module.

PROBLEM	TEST	TEST INDICATION	CORRECTIVE ACTION (Fig. 3)
No function from Display Module	Section 7.1 A	No display or no communications*	Replace display board (10)
No response from one or more keys	Section 7.1 B	Missing or wrong key identifier	Replace display board (10)**
No current loop function	Section 7.1 C	Timing does not change or changes incorrectly	Replace display board (10)
No One-Step function	Section 7.1 D	Timing does not change	Replace display board (10)

* Display Module reads "COMMUNICATIONS PROBLEM"

** May indicate a defective display board or defective keypad

CPU-95 DIGITAL IGNITION SYSTEM

9.0 BOARD REPLACEMENT PROCEDURE IGNITION MODULE LOGIC BOARD

9.1 DISASSEMBLY PROCEDURE (REFER TO FIGURE 2)

- A. Remove four screws (8) from cover board (9) and remove cover board.
- B. Remove four standoffs (10) from logic board (11).
- C. Carefully unplug four conductor ribbon cable from logic board and fifteen conductor ribbon cable from power board (14). Logic board can now be removed from enclosure (3).
- D. Remove four screws (21) and separate logic board from shield board (12).

9.2 ASSEMBLY PROCEDURE (REFER TO FIGURE 2)

- A. Attach shield board (12) to logic board (11) using four screws (21).
- B. Install logic board in enclosure (3).
- C. Plug fifteen conductor ribbon cable into power board (14) and four conductor ribbon cable into logic board.
- D. Install and tighten four standoffs (10).
- E. Replace cover board (9) and secure with four screws (8).
- F. Retest per SECTION 4.0.

10.0 BOARD REPLACEMENT PROCEDURE IGNITION MODULE POWER BOARD

10.1 DISASSEMBLY PROCEDURE (REFER TO FIGURE 2)

- A. Remove logic board (refer to section 9.1).
- B. Remove four screws (22, 23) from bottom of enclosure (3).
- C. Remove four standoffs (13).
- D. Remove four screws (4a) from connector on side of enclosure and push connector into box.
- E. Power board (14) can now be removed from enclosure.

10.2 ASSEMBLY PROCEDURE (REFER TO FIGURE 2)

- A. Wipe inside of enclosure with a clean rag. Examine insulators (24, 25) and replace if damaged.
- B. Insert power board (14) into enclosure (3).
- C. Install four new screws (22, 23) through bottom of enclosure and tighten securely.
- D. Replace connector gasket (4) and insert connector through enclosure hole. Orient connector key to top of enclosure.
- E. Using four new screws (4a) secure connector in enclosure.
- F. Install four standoffs (13) and tighten power board securely.
- G. Install logic board (REFER TO SECTION 9.2).
- H. Retest per section 4.0, 6.0.

11.0 BOARD REPLACEMENT PROCEDURE DISPLAY MODULE DISPLAY BOARD

11.1 DISASSEMBLY PROCEDURE (REFER TO FIGURE 3)

- A. Loosen four screws (5) holding front cover (2) to back enclosure (12). Leaving screws in front cover pull back enclosure away.
- B. Remove three screws (8) holding display board assembly (10).
- C. Unplug keypad ribbon cable and remove display board assembly.

11.2 ASSEMBLY PROCEDURE (REFER TO FIGURE 3)

- A. Plug keypad ribbon cable into display board assembly (10).
- B. Install and tighten three screws (8) securing display board assembly.
- C. Verify back enclosure and front cover gaskets (11, 6) are in good condition and replace if necessary.
- D. Place front cover (2) and back enclosure (11) together and start four screws (5).
- E. Verify front cover gasket is aligned and alternately tighten four screws (2) until secure.
- F. Retest per **SECTION 7.0**.