

Operating Manual

Altronic Gas Control Valve, 690153

altronic
HOERBIGER Engine Solutions



1.0 Overview

1.1 This manual provides installation instructions and maintenance information for the Altronic Gas Control Valve, model 690153-1. It is recommended that the user read this manual in its entirety before commencing operations.

It is not our intention to instruct others on how to design control systems, nor can we assume responsibility for their safe operation. This advice is intended to help the end user install the Altronic Gas Control Valve in such a manner to reduce the risk of accident to personnel or to equipment.

Do NOT attempt to operate, maintain, or repair the fuel control valve until the contents of this document have been read and are thoroughly understood.

1.2 Altronic Gas Control Valves are normally used with natural gas. Natural gas and air, when combined, become very combustible and, when contained within an enclosure such as a gas engine or its exhaust system, can explode in a violent manner when ignited. It is necessary to always use extreme caution when working with any fuel system. The control systems used with gas engines or other similar machines should always be designed to be “fail-safe”.

1.3 The Gas Control Valve is **NOT** a shutoff valve. Shutoff valves must be used in addition to the control valve. The fuel system should be designed in such a way that:

- no failure of a single component will cause the fuel system to admit fuel to the engine when the engine has been shutdown, and
- no single failure can result in grossly over-fueling the engine when attempting to start.

WARNING: Failure to follow the above rules may lead to serious damage to equipment or to personnel.

1.4 Valve 690153-1 is recommended for use on applications below 250 HP.

1.5 Maximum gas working pressure is 40 psig. Gas pressure at the valve must **NOT** exceed this rating at any time.

2.0 Installation

2.1 The Gas Control Valve should be inspected immediately after unpacking. Check for any damage that may have occurred during shipping. If there are any questions regarding the physical integrity of the valve, contact the distributor or Altronic, Inc.

2.2 The Gas Control Valve is designed to be installed on natural gas fired, reciprocating engines. It is a flow-control device that responds directly to the control output of the Altronic EPC series of products. Additionally, by the use of a special adaptor device, Altronic P/N 691156-1, the valve can be made to control based upon a 4–20mA signal from a general purpose controlling device such as a PLC. In all cases the valve is installed between the fuel supply pressure regulator and the carburetor and is used to throttle the fuel available to the engine. When considering where to place the Gas Control Valve, choose a location away from any extreme sources of heat. Operating ambient temperature is -40°F to +176°F (-40°C to +80°C). Do not expose the valve to temperatures higher than indicated in this manual.

WARNING: DEVIATION FROM THESE INSTALLATION INSTRUCTIONS MAY LEAD TO IMPROPER ENGINE OPERATION WHICH COULD CAUSE PERSONAL INJURY TO OPERATORS OR OTHER NEARBY PERSONNEL.

NOTE: If possible, keep the original shipping container. If future transportation or storage of the valve is necessary, this container will provide the optimum protection.

3.0 Mounting the Gas Control Valve

- 3.1 In order to control the air/fuel ratio, the electronically-controlled valve is connected in series between the regulator and carburetor or mixer. The valve should be installed as close to the fuel inlet of each carburetor or mixer as possible. The distance from the valve to the carburetor inlet should not exceed 12 pipe diameters in length. The preferred mounting of the valve is in the vertical position, with the flow direction being up or down. Horizontal mounting of the valve is acceptable as long as the valve is NOT installed with the control cable connector facing downward. This is necessary to avoid the collection of condensation in the electronics housing. **See FIG. 1 for dimensional details.**
- 3.2 If possible, gas connection piping should be of the same diameter as that currently in use. The 690153-1 valve has 3/4-inch NPT threads. In some applications, the threaded connection to the valve body may require the use of thread adapters. If adapters are used, proper plumbing procedures must be followed.
- 3.3 Each control valve is connected to the EPC Series using 693005-x cable. This cable has connectors on both ends and in unshielded installations these connectors are simply plugged into the valve and the EPC unit. In applications where the cable will be enclosed in conduit, use 693013-1 cable, which is 30' long with a connector at one end only. The cable is color-coded and must be connected inside a junction box with each wire color matching. This cable must not be run in the same conduit as the ignition primary or other wires. A distance of 4" to 6" should be maintained between EPC Series wiring and other engine wiring. Note that the upper connector on the EPC Series controls the stepper valve for single control channel applications and the left bank valve on V-engines.

4.0 Power Supply

- 4.1 The circuitry of the valve is powered directly by the EPC Series or the output of the Stepper Motor Controller 691156-1. No additional external power source should ever be connected to the valve.

5.0 Flow Characteristics

- 5.1 *See the flow capacity curve, FIG. 3, in the drawings section.*

6.0 Gas Valve Service and Repair Overview

- 6.1 The Gas Control Valve has been designed to provide reliable operation with a minimum amount of maintenance. To ensure optimum performance, periodic inspection and cleaning is necessary. Preventative maintenance issues can be integrated into the current maintenance schedule of the engine. Most maintenance requires little effort and minimal downtime of the valve. Corrective maintenance is to be done when the Gas Control Valve begins to behave erratically. Procedures have been generated to cover most minor issues.
- **External Visual Inspection** – Inspect the exterior of the Gas Control Valve for loose connections, frayed wires or structural damage.
 - **Cleaning** – Exterior cleaning will aid in the visual inspection of the external casing and ensure good connections. Mild soapy water can be used as a cleaning agent.
 - **Maintenance Log** – To facilitate troubleshooting and to establish service schedules, a maintenance log should be kept on the Gas Control Valve. Throughout this manual, service parts will be identified by the figure number and item number assigned in the parts list. Items will be referred to by the figure number followed by a hyphen and the item number that it refers to. For example, (2-5) and its position on the Gas Control Valve can be found by locating item 5 on FIG. 2 and looking for its description and part number as identified in the table.

7.0 SERVICING THE GAS CONTROL VALVE

7.1 The Altronic Gas Control Valve is set from the factory and generally does not need adjustment, however periodic maintenance may be needed depending on the service application and quality of the fuel passing through the valve. By following the recommended mounting positions and supplying clean gas this valve will provide excellent service.

7.2 The service kit for the Gas Control Valve includes:

Motor/Connector/Piston Assembly P/N 680014-1 (690153-1 Valve)

Other parts are available as individual items.

8.0 Disassembly of Gas Control Valve

8.1 This section covers the disassembly of the Gas Control Valve for purposes of field service or maintenance. This valve was designed to be serviceable while connected to the gas pipeline **providing that the gas flow has been shut off to the valve. Failure to shut off the gas flow can cause a very dangerous situation.** If servicing is to be done with the valve removed from the gas pipeline, then it is recommended that a clean flat work surface be prepared and the proper tools be made available.

8.2 This is a recommended tool list to disassemble the 690153 series Gas Control Valves:

- #2 Phillips-head screwdriver
- 7/32" wide flat-blade screwdriver
- 5/32" T-handle hex wrench (Allen wrench)
- Loctite® 222 small screw (service removable) thread locker

8.3 With the stepper motor in its fully retracted position (valve fully open), remove the four 8-32 seal screws (2-8) that secure the connector to the cover. Next remove the six 10-32 socket head cap screws (2-9) that fasten the cover (2-2) to the valve housing (2-1). Note gasket (2-6) between connector and cover. There is also a gasket (2-5) between the cover and the valve housing.

8.4 With the cover (2-2) removed, the inner workings of the valve are now exposed. Keep this area free from contaminants such as excessive dirt and moisture. Remove the two 6-32 pan head screws (2-7). This will allow removal of the Motor/Connector/Piston Assembly (2-3) from the valve housing (2-1). Having available a spare Motor/Connector/Piston Assembly (2-3) will minimize downtime.

9.0 Reassembly of Gas Control Valve

9.1 Replace the Motor/Connector/Piston Assembly (2-3) into the valve housing (2-1). Secure the motor using the two 6-32 pan head screws (2-7). NOTE: Apply a small amount of Loctite® 222 to each screw before installation.

9.2 Replace the connector into the cover (2-2), taking care to properly mount the connector gasket (2-6) between the connector and the cover. Secure the connector to the cover using the four 8-32 Phillips head seal screws (2-8).

9.3 Attach the cover (2-2) to the valve housing (2-1), taking care to properly mount the cover gasket (2-5) between the valve housing and the cover. Secure the cover using the six 10-32 socket head screws (2-9). **See tightening sequence and torque specification on FIG. 2.**

9.4 Before returning the valve to service, the valve should be thoroughly leak tested using a soapy water solution. Brush a small amount of this solution onto the area to be tested. A constant bubbling of the liquid indicates a leak. Do not submerge the valve in the test solution. Carefully check the area around the cover gasket and around the connector.

FIG. 1 3/4" Fuel Control Valve Detail

Media Compatibility	Aluminum Body, Cover and Piston Corrosion Resistant Stepper Motor
Electrical Specification	12/24volts @ 5watts max.
Max. Working Pressure	40psig
Max. Operation Temperature	- 40°F to 176°F

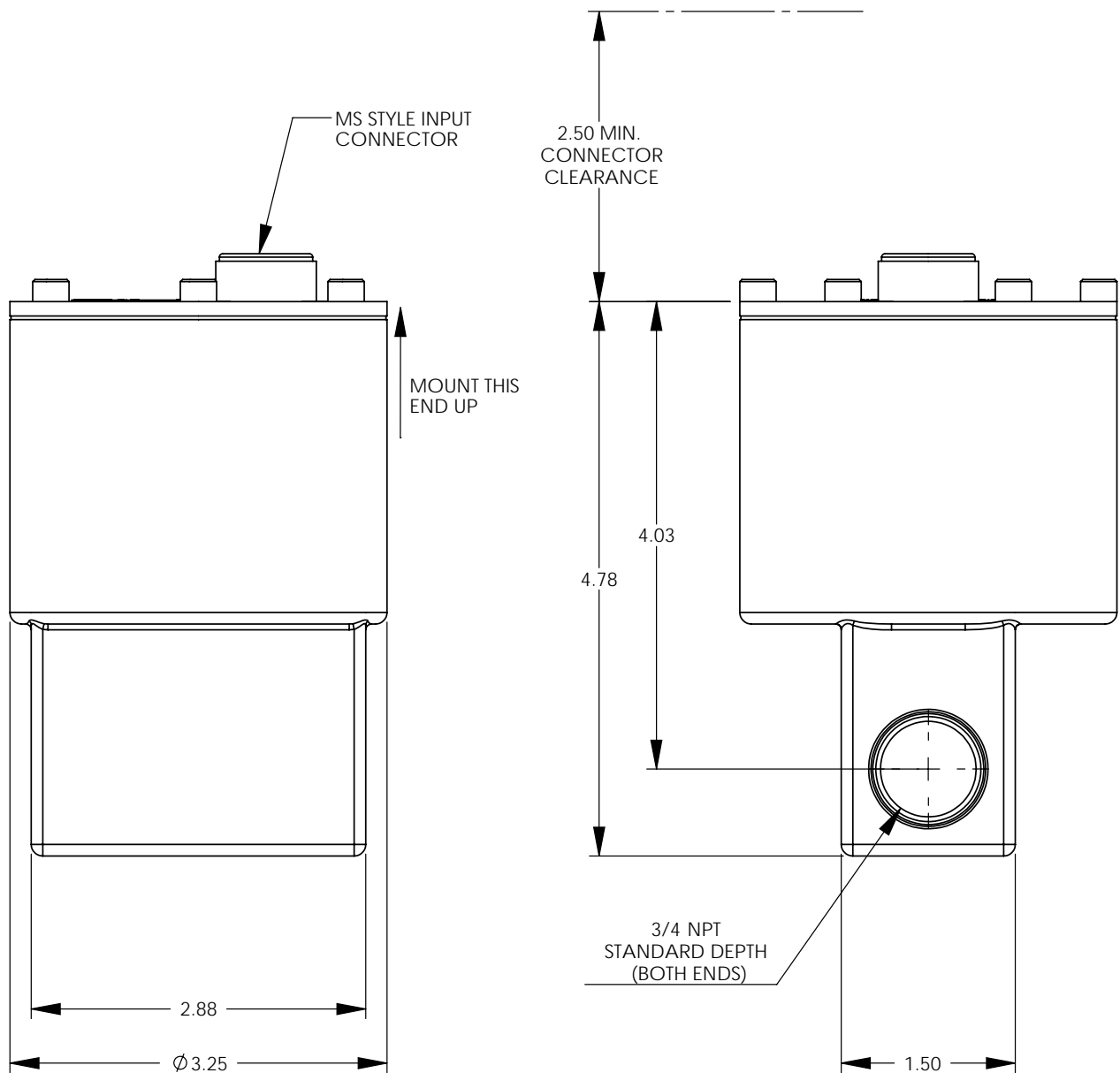

FIG. 2 Part Breakdown and Identification – 3/4" Fuel Control Valve

ITEM NO.	QUANTITY	PART NO.	DESCRIPTION
1	1	615155	Housing, Machined
2	1	615165	Cover
3	1	680014-1	Motor/Connector/Piston Assembly
4	1	602 707	Label
5	1	615166	Gasket, Cover
6	1	501355	Gasket, Connector
7	2	902732	Screw, 6-32 x 1/4 pan hd
8	4	902641	Screw, 8-32 x 3/8 flat hd
9	6	902729	Screw, 10-32 x 1/2 cap

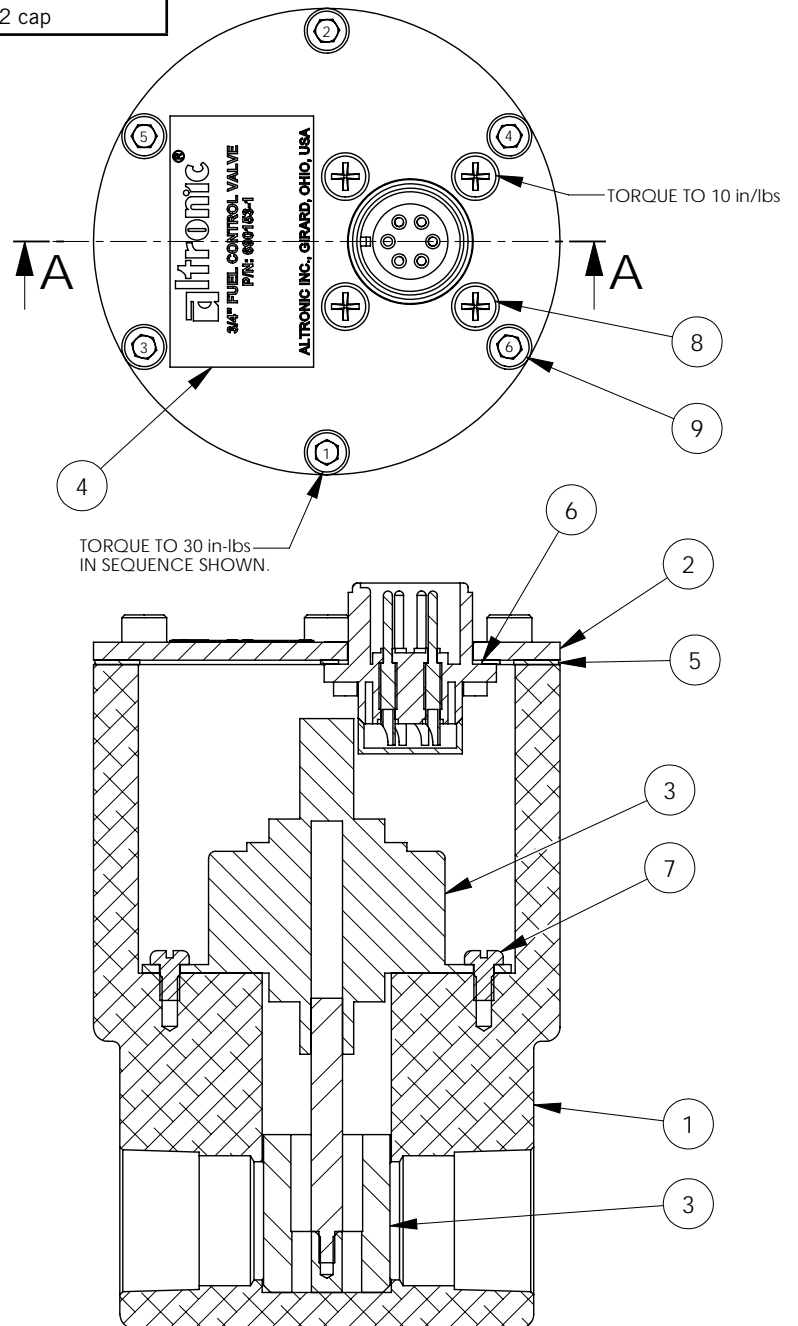

FIG. 3 Flow Curve for 690153-1

