



## UNIVERSAL DIGITAL TACHOMETERS DTHO 1201/3201 SERIES

- **Two universal models**
  - **C.D. ignition or magnetic pickup-based input power and RPM pulses**
  - **4-1/2" round or JIC rectangular Lexan cases**
  - **Includes integral overspeed trip and hourmeter**
  - **Quartz crystal design eliminates all calibration requirements**
- **Reduces spares requirements**
- **Simple to configure**
- **Suitable for use on gas engines and other critical rotating equipment**
- **CSA certified for Class I, Divisions 1 and 2, Groups C and D hazardous areas**

The DTHO 1201/3201 series tachometers represent the third generation of digital speed sensing and indication devices from Altronic. Designed for universal use, these high-quality, microprocessor-based devices can be powered from either a C.D. ignition "shutdown lead" or a magnetic pickup, and are offered in two durable Lexan enclosures for use on natural gas engines and other critical rotating equipment. Overspeed trip and hourmeter functionality is resident in both devices.

- Model **DTHO-1201** features a weather resistant 4-1/2" round case which can be mounted in an industry-standard cutout. This device replaces the former DT/DTH/DTO/DTHO-1200-series tachometer instruments.
- Model **DTHO-3201** is packaged in a 4.19" X 5.00" Lexan case. It replaces former types DTO-1010, DT/DTH/DTO-3200 and the PT/PTH/PTO/PTHO-2100 series pickup input-based devices.

Setup of these highly accurate devices is simple and is accomplished through a front-mounted, sealed membrane keypad. Either device can be configured for use in monitoring engine RPM or higher speeds of interest, including turbocharger RPM. An advanced filtering algorithm assures a stable speed readout even during periods of speed input fluctuation.

Both the DTHO-1201 and 3201-series devices are certified as safe for use in Class I, Divisions 1 and 2, Groups C and D hazardous areas by Canadian Standards Association (CSA).

NOTE: See also the DSG-1201 microprocessor-based tachometer series – form DSG12.



ENGINE OR PRIME MOVER RPM



TURBOCHARGER RPM



OPERATING HOURS



CERTIFIED CLASS I,  
DIVISIONS 1 and 2  
GROUPS C and D

## DIMENSIONS

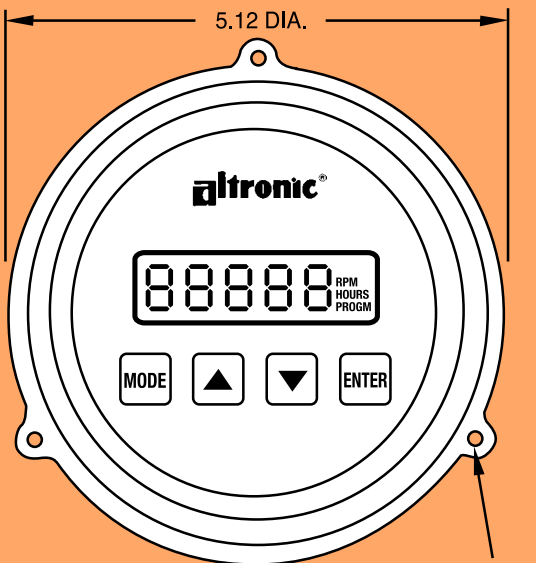

MOUNTING REQUIRES CLEARANCE HOLES FOR 10-32 MOUNTING SCREWS. 3 HOLES, 120° APART ON 5.20" D. BOLT CIRCLE.

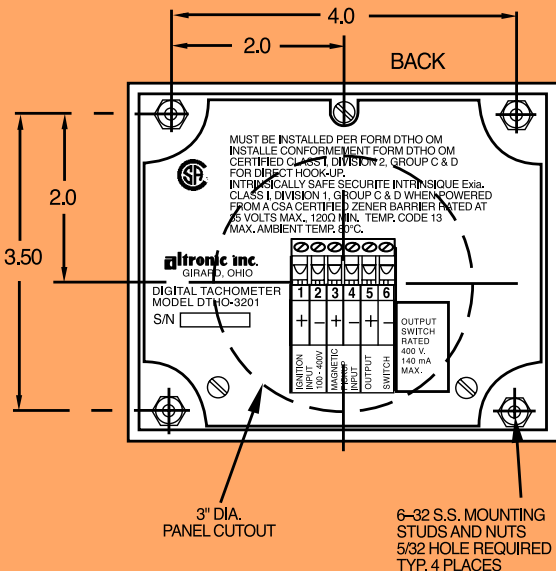
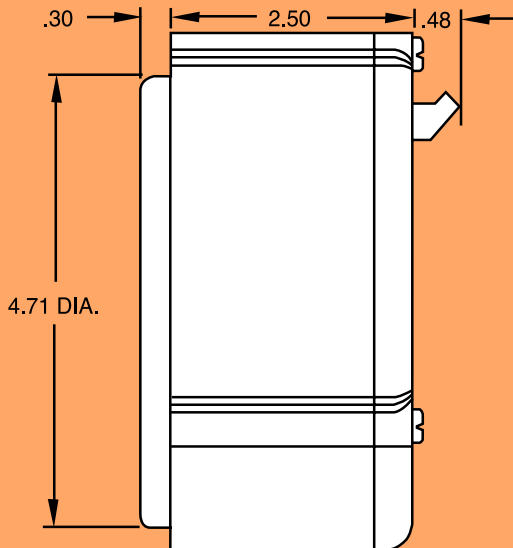

## SPECIFICATIONS

POWER REQUIREMENT .....	NEGATIVE OR POSITIVE C.D. IGNITION SHUTDOWN LEAD (100-400V.) OR MAGNETIC PICKUP (3-20V. PEAK)
CONFIGURATION .....	PROGRAMMABLE INPUT PULSE COUNT
HAZARDOUS AREA CLASSIFICATION	
IGNITION POWER/INPUT .....	CLASS I, DIVISION 2, GROUPS C AND D SEE "TO ORDER" INFORMATION BELOW FOR CLASS I, DIVISION 1, GROUPS C AND D
MAGNETIC PICKUP POWER/INPUT .....	CLASS I, DIVISION 1, GROUPS C AND D (WHEN POWERED FROM ALTRONIC 691118 MAGNETIC PICKUP)
INSTRUMENT DISPLAY .....	0.4" 5-DIGIT LCD WITH DISPLAY INDICATORS
INSTRUMENT RANGE	
RPM INDICATION .....	0-9999 (ENGINE), 0-99,900 (TURBO)
HOURS INDICATION .....	0-99,900 (SETABLE)
INSTRUMENT ACCURACY .....	±0.5%, ±1 DIGIT
DISPLAY UPDATE RATE .....	1 PER SECOND (WITH DISPLAY FILTER)
OVERSPEED SETPOINT .....	1 USER-PROGRAMMABLE
OUTPUT SWITCH RATING .....	400 VDC, 140mA CONTINUOUS (N.O.)
AMBIENT TEMPERATURE RANGE .....	-40°TO +175°F (-40° TO +80°C)

## TO ORDER

### TACHOMETER/HOURMETER WITH OVERSPEED:

4-1/2" Round Case .....	DTHO-1201
Rectangular Case .....	DTHO-3201

### CLASS I, Division 1, Group C and D HAZARDOUS AREA APPLICATION

Intrinsically Safe Option for DTHO-1201/3201, use Altronic Barrier:

Neg. Ground Ignition .....	690107
Pos. Ground Ignition .....	690108
Cable Assembly .....	693106-1

Class I, Group C and D Enclosure Option: Add -X to above device part no.

### PNEUMATIC INTERFACE

Use solenoid valve listed below; suitable for Class I, Division 1, Group C and D hazardous areas.

2-way Valve .....	690019-1
3-way Valve .....	690019-2

### MAGNETIC PICKUPS AND CABLES

#### MAGNETIC PICKUPS:

5/18"-18 X 1.75" .....	691118-1
5/18"-18 X 2.50" .....	691118-2
5/18"-18 X 3.00" .....	691118-3
5/18"-18 X 4.50" .....	691118-4
5/18"-18 X 6.00" .....	691118-6

#### PICKUP CABLES:

10 ft. length .....	693104-1
20 ft. length .....	693104-2
30 ft. length .....	693104-3
40 ft. length .....	693104-4
50 ft. length .....	693104-5



712 TRUMBULL AVE / GIRARD, OH 44420  
(330) 545-9768 / Fax: (330) 545-9005  
www.altronicinc.com E-mail: sales@altronicinc.com

FORM DTHO 02-03